

# Introduzione alla Realtà Virtuale

## Parte I

Prof. Alberto Borghese  
alberto.borghese@unimi.it





# Sommario



- **Introduzione**
- Sistemi di Input
- Generatori di mondi
- Motore di calcolo
- Sistemi di Output
- Conclusioni



# Which is real, which is virtual?

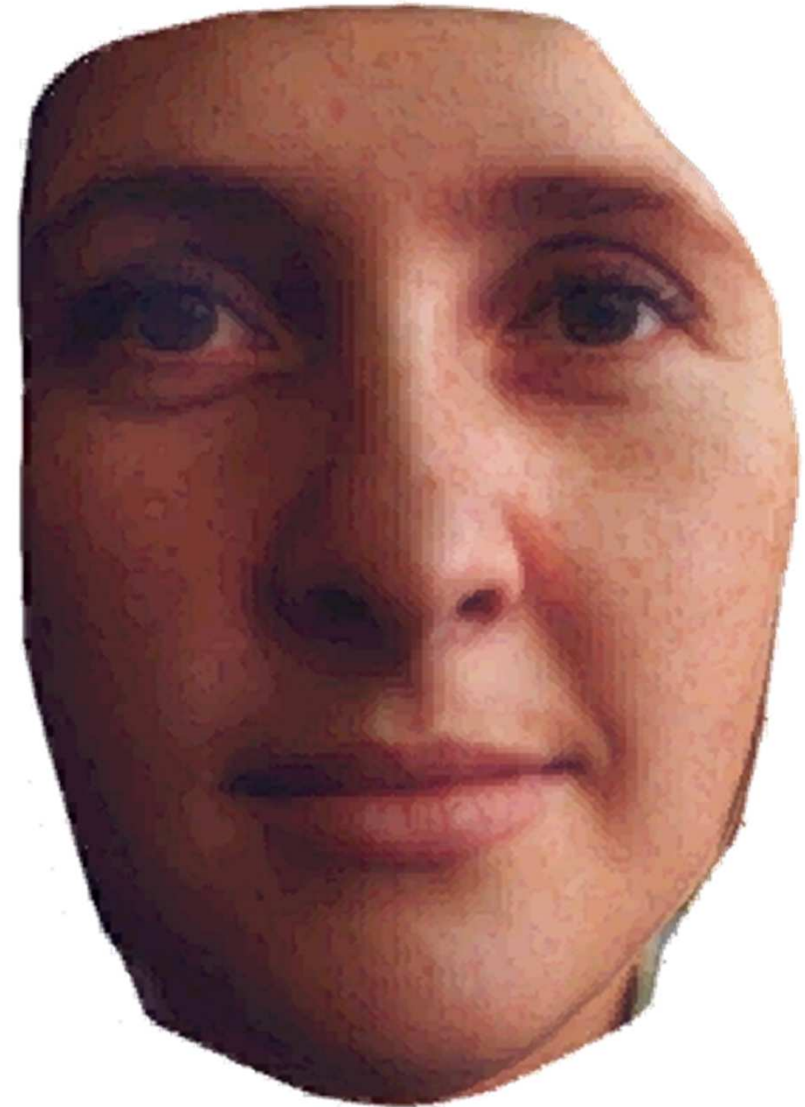



# Historical Perspective (I)



- *The name “Virtual Reality” has been attributed to Jaron Lanier (VPL), 1986.*
- *Virtual Worlds or Synthetic Environments*
- *Philosophical and Technological origin.*

## *Philosophical background*

### *Ontology and Gnoseology.*

- Plato (world of the ideas) 428-348 a.C.
- Berkeley (sensorial experience is too limited) 1685-1753.
- Hegel (“what is rational is real..”) 1770-1831.
- New age.

# Historical Perspective (II)

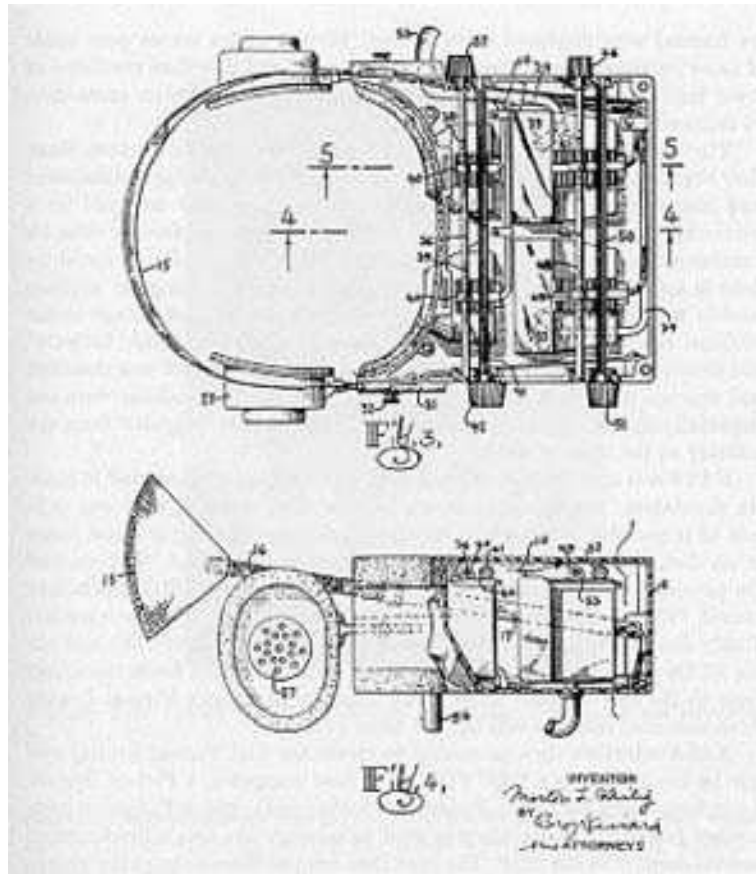

Morton Heilig 1956,  
patented in 1961  
Non fu mai costruito

projected film,  
audio, vibration,  
wind, odors.





# Historical Perspective (III)



## *Technological background*

- *Philco HMD, 1961.*
- *“Ultimate display”, Sutherland, 1970.* →
- *Data Glove, VPL Research, 1988.*



Sutherland, Ivan E. 1968. "A Head-Mounted Three Dimensional Display," pp. 757-764 in Proceedings of the Fall Joint Computer Conference. AFIPS Press, Montvale, N.J.



# Virtual Reality Systems



Key characteristics are:

Immersivity.

Interactivity.

VR should be able to stimulate the human sensorial systems  
In a coordinated way.

VR output should be able to saturate our sensor systems, congruently.



# A typical VR system



## VR systems are constituted of:

- *Input systems* (measure the position *in* the environment and force *over* the environment).
- *World generators* (provides a realistic virtual world in which to act).
- *Computational engine* (computes the output, given the input and the virtual world).
- *Output systems* (outputs sensorial stimuli *on* the subject. Vision, sound, force ... are generated as if they were provided *by* the virtual environment).





# Sommario



- Introduzione
- **Sistemi di Input (trackers)**
- Generatori di mondi
- Motore di calcolo
- Sistemi di Output
- Conclusioni





# Input systems



Measure human actions on the virtual environment.

- **Position.** Measure the position of the body segments inside the virtual environment.
- **Force.** Measure the force exerted by the body segments when in contact with a virtual object.
- Estimate the motor output of the human muscle-skeleton system.



# Tracking systems



- Measure the position of the body segments inside the virtual environment.
- **Motion capture** (batch, complete information on the movement).
- **Real-time trackers** (real-time position of the body).
- **Gloves** (specialized for hands).
- **Gaze trackers**.

## Adopted technology

- Optoelectronics (video-camera based)
  - Marker based
  - Computer vision
  - Scanner based.
- Magnetical
- Acoustical
- Mechanical
- Inertial





# What is motion capture?

Ensemble of techniques and methodologies to acquire **automatically** the motion of the objects of interest.

Characteristics: sampling rate, accuracy, 2D/3D, real-time, motion amplitude, invasivity,....

Technology: opto-electronical, magnetical, ultrasound, inertial ....

Specific body parts: gloves, gaze trackers....

Applications are increasing (medical applications at the origin, now interest in the entertainment, robotics, reverse engineering ...)



# Motion Capture and Synthesis



Reproduce digitally the motion of the body (in real-time in case of tracker).

Time series of the position of the body segments  
or  
Time series of the motion of the articulations.

Analysis  
Info extraction

Application of the time series to a  
3D digital model of the body.

Synthesis  
Avatar animation





# Uncanny Valley



**POPULAR  
SCIENCE** **THE  
FUTURE  
NOW**



# Avatar designed avoiding the "uncanny" valley

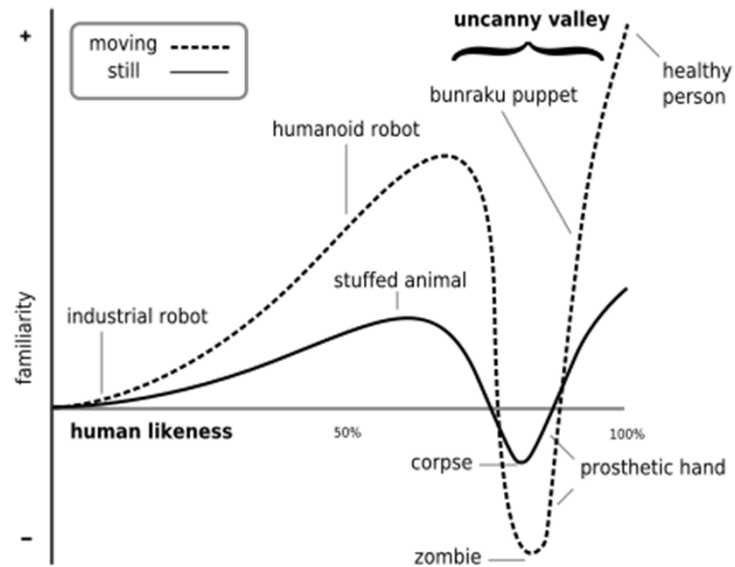

Mori, Masahiro (1970). Bukimi no tani The uncanny valley (K. F. MacDorman & T. Minato, Trans.). *Energy*, 7(4), 33–35. (Originally in Japanese)



# What is captured?

Silhouette (-> Skeleton)

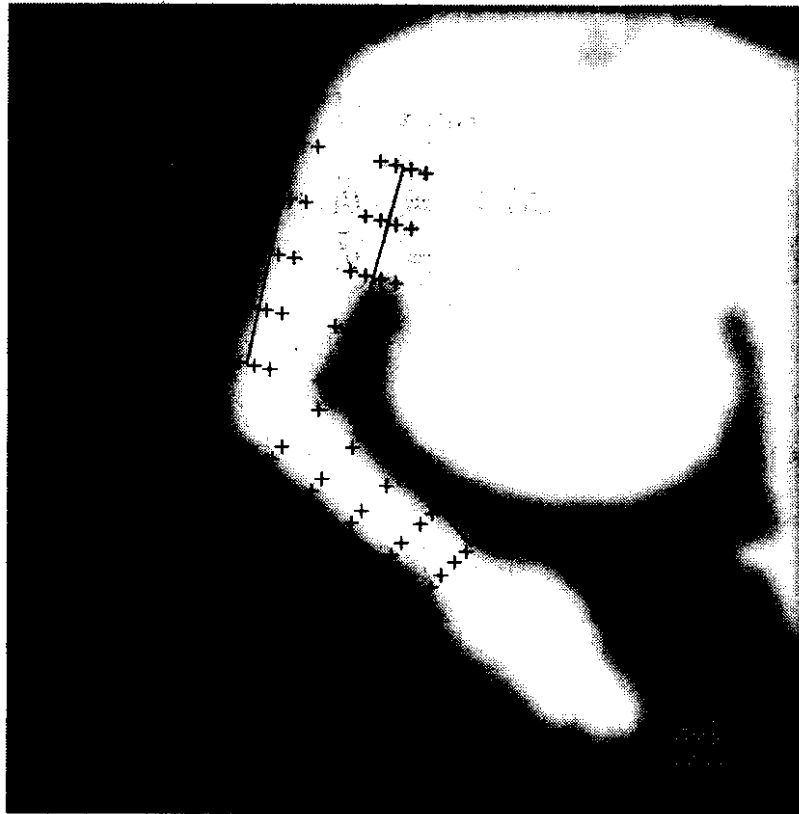

Computer vision techniques  
(silhouette)

Skeleton

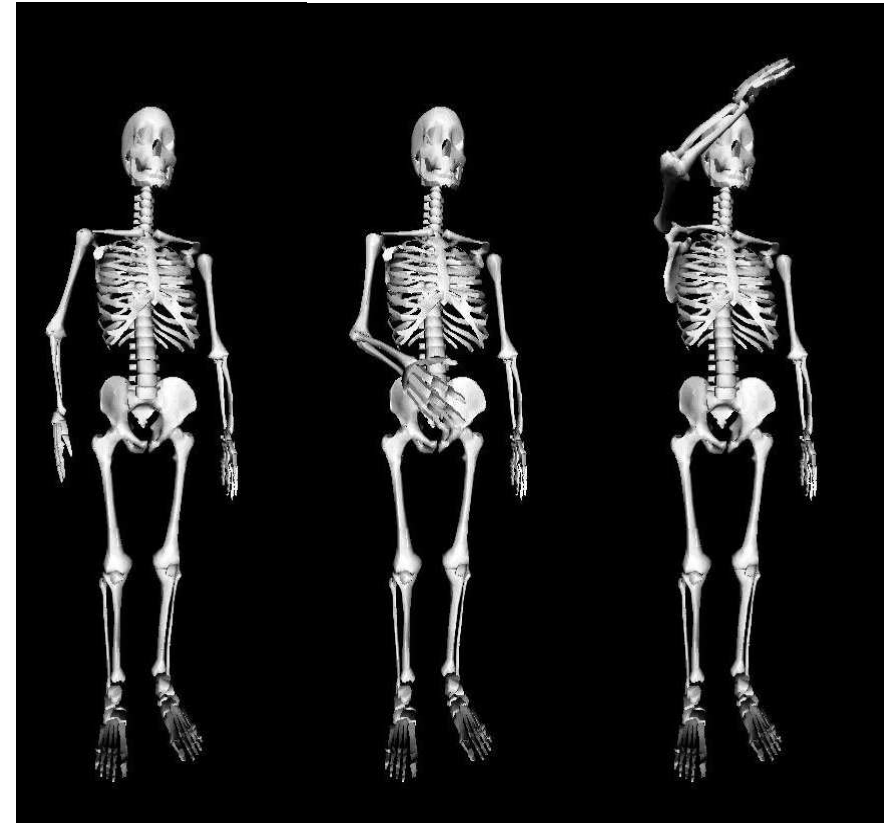

Bony segments or articulations  
(marker-based systems / Kinect)



# Description of the human skeleton

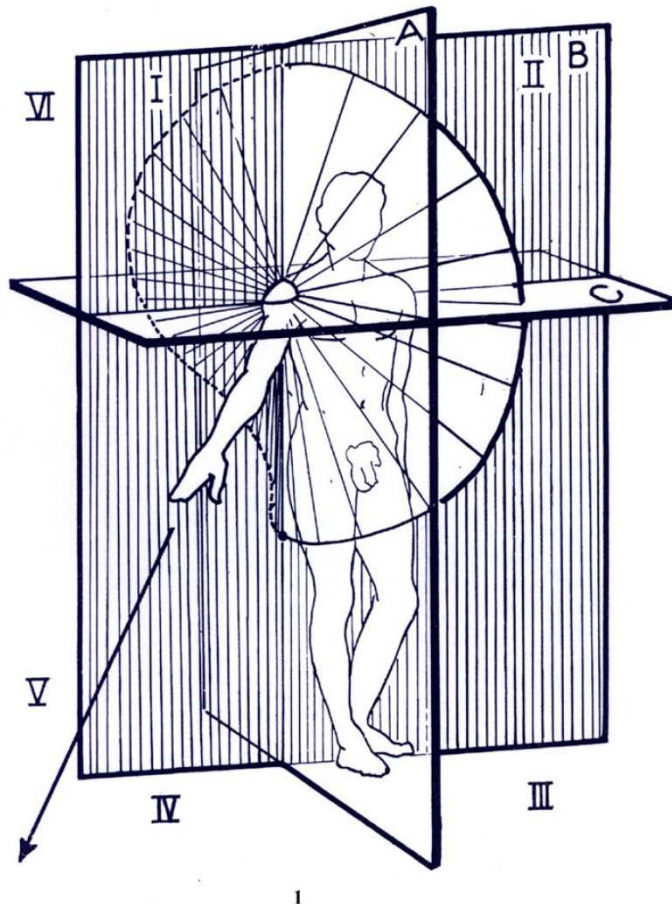

A – Frontal plane  
B – Sagittal plane  
C – Horizontal plane

Abduction/adduction

Flexion/extension

Axial rotation (V)

Quaternions for 3D rotations

3D position of joint extremes

Definition of the interesting degrees of freedom.



# Why passive markers?



Minimum encumbrance on the subject: markers do not require any powering and are hardly sensed by the subjects.

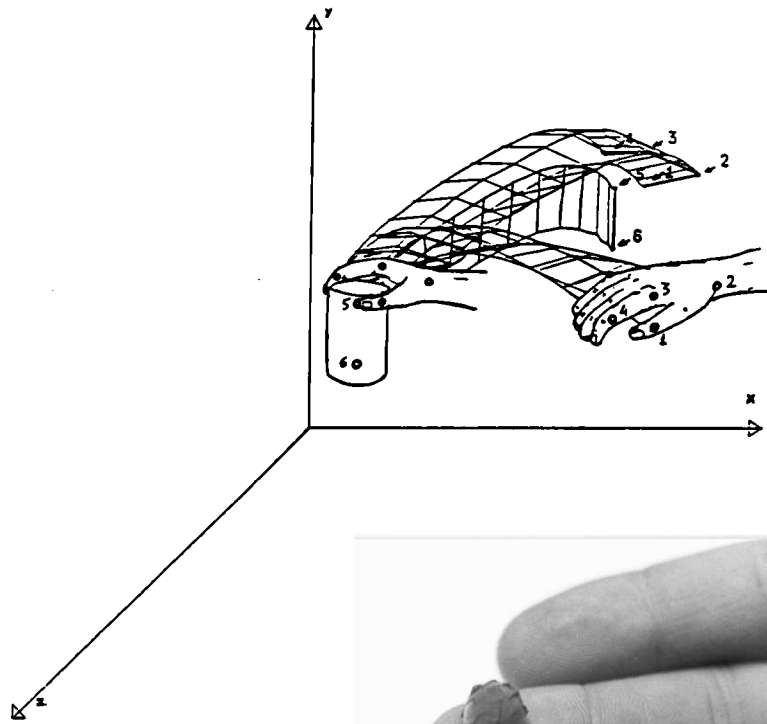

No constraint on the dimension of the working volume is prescribed.

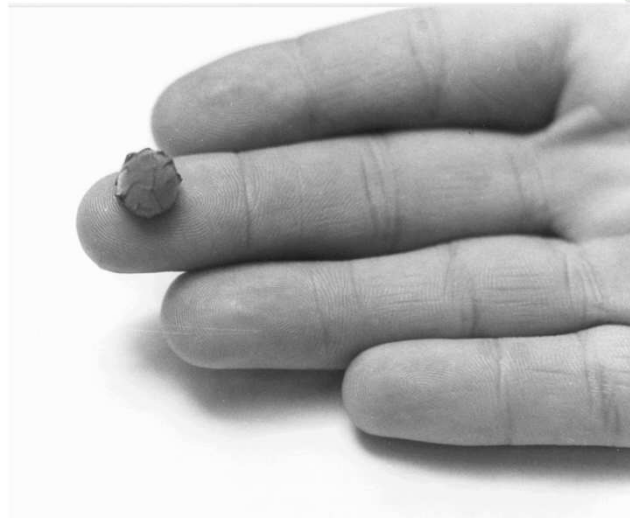





# How passive markers work?



Passive markers are constituted of a small plastic support covered with retro-reflecting material (3M™). It marks a certain rephere point.

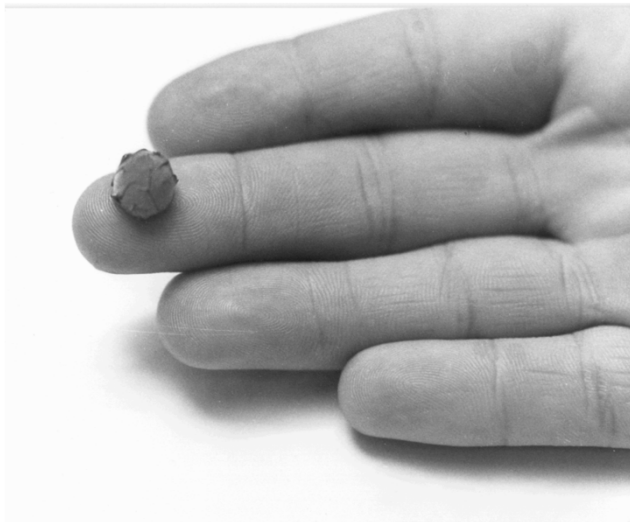

Video-cameras are equipped with a co-axial flash.

Markers appear much brighter than the background making their detection, on the video images, easier.



# Motion Capture through markers



<http://www.vicon.com/applications/games.html>

Vicon system from Oxford Metrix



# Tracking difficulties



It is a complex problem because:

- Dense set of markers. These may come very close one to the other in certain instants.
- Motion can be easily complex, as it involves rotation and twists of the different body parts (thing at a gymnastic movement).
- Multi-camera information and temporal information is required to achieve a robust tracking.

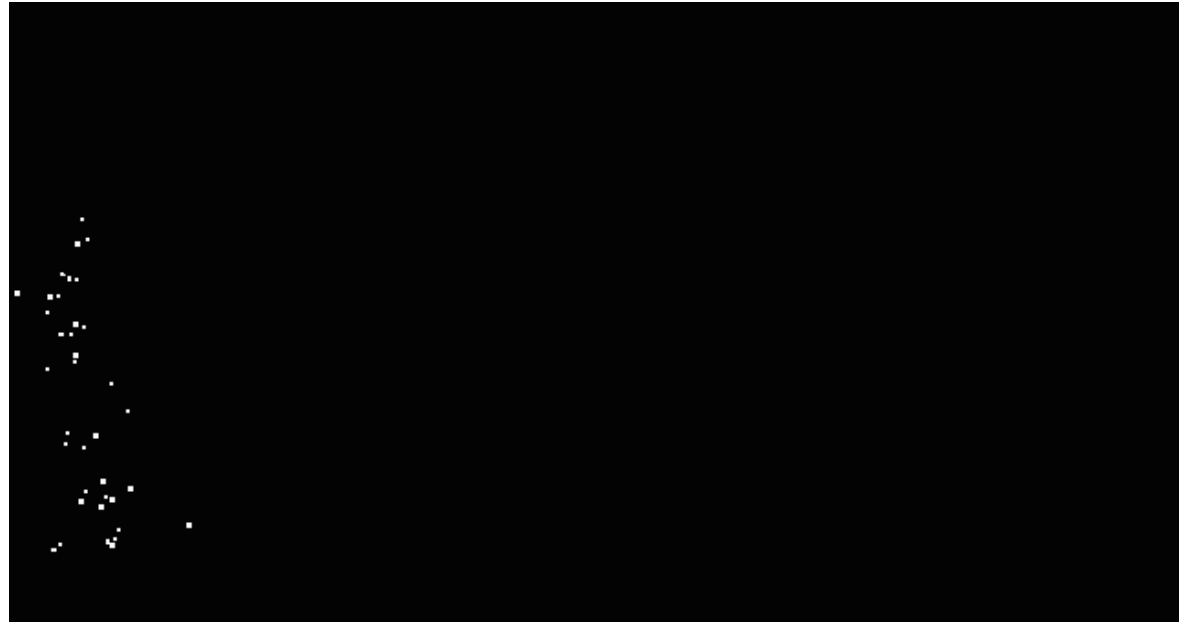



# Tracking difficulties



It is a complex problem because:

- Dense set of markers. These may come very close one to the other in certain instants.

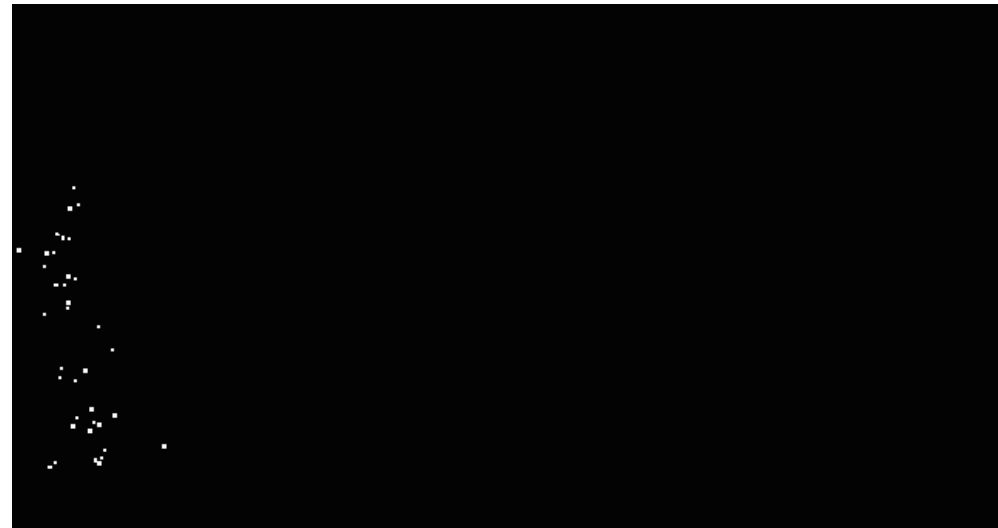

- Motion can be easily complex, as it involves rotation and twists of the different body parts (thing at a gymnastic movement).
- Multi-camera information and temporal information is required to achieve a robust tracking.



# Sequential processing



1. Surveying the image of the moving subject on multiple cameras (*frequency & set-up*).
2. Markers extraction from the background scene (*accuracy & reliability*).
3. Computation of the “real” 2D position of the markers (*accuracy <- distortion*).

Low-level  
Vision

4. **Matching on multiple cameras.**
5. 3D Reconstruction (*accuracy*).

High-level  
Vision

6. **Model fitting (*labelling, classification*).**

Semantic

An implicit step is CALIBRATION.





# Disadvantages of motion capture systems based on passive markers



When a marker is hidden to the cameras by another body part (e.g. the arm which swings over the hip during gait), the motion capture loses track of it.

The multiple set of 2D data have to be correctly labeled and associated to their corresponding 3D markers.

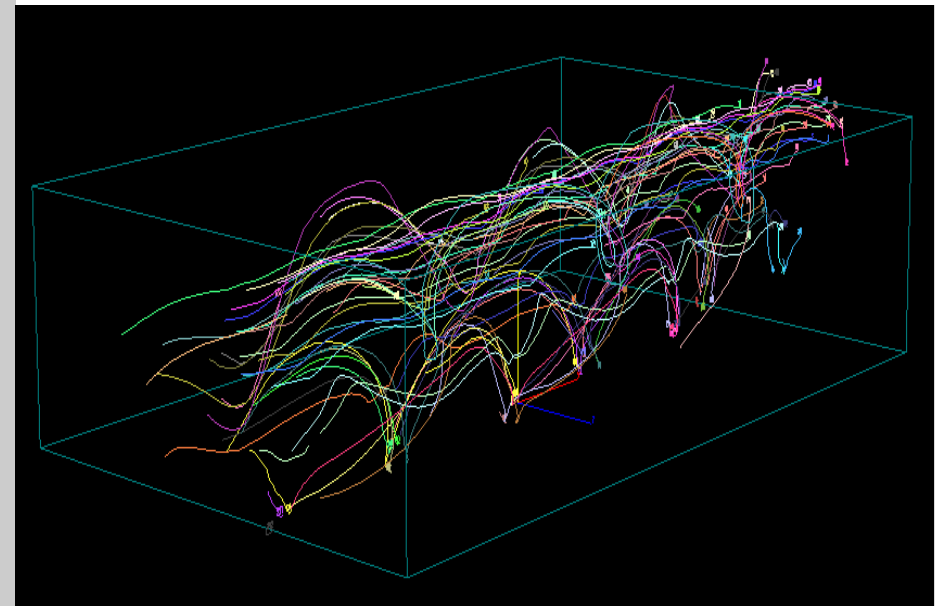
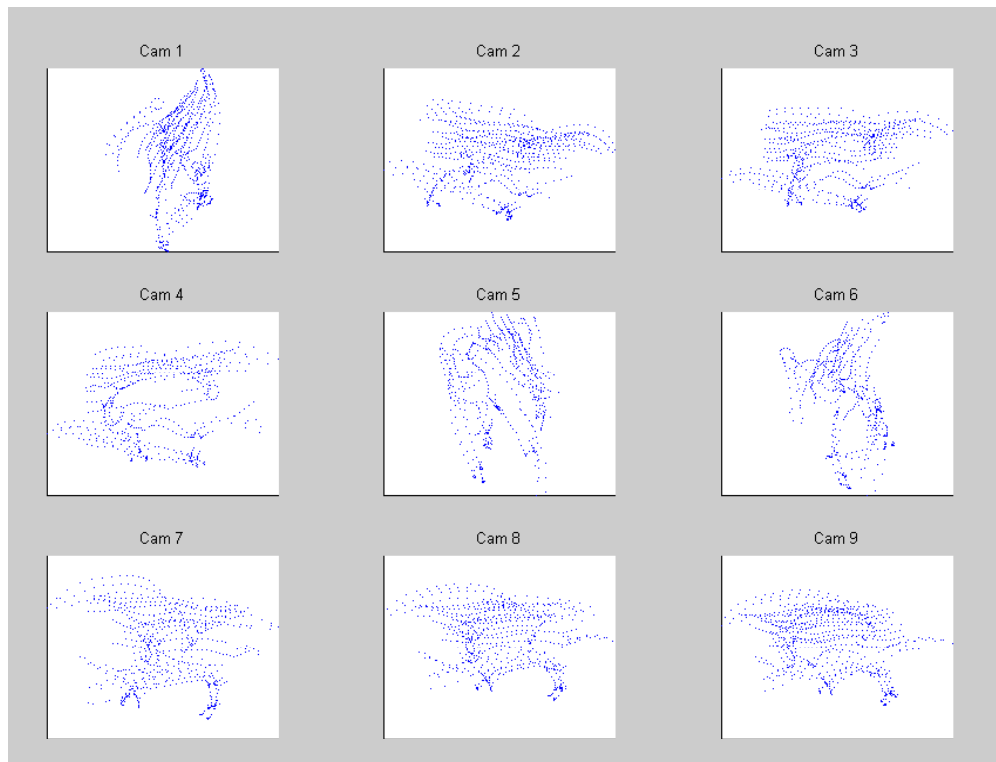



# Tracking difficulties



It is a complex problem because:

- Dense set of markers. These may come very close one to the other in certain instants.

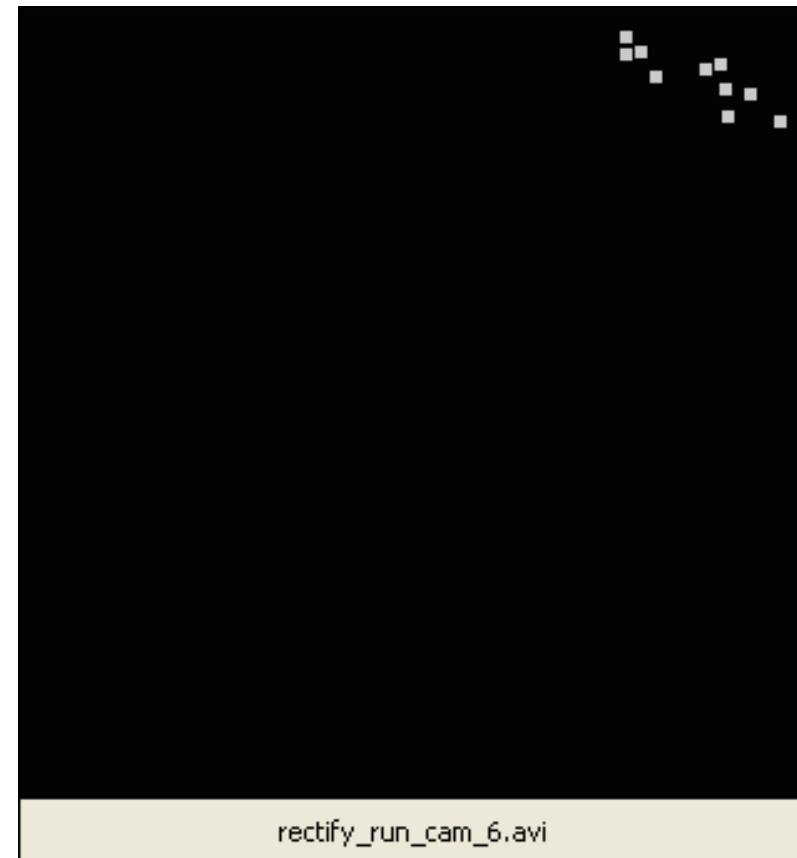

- Motion can be easily complex, as it involves rotation and twists of the different body parts (thing at a gymnastic movement).
- Multi-camera information and temporal information is required to achieve a robust tracking.



# 2D tracking

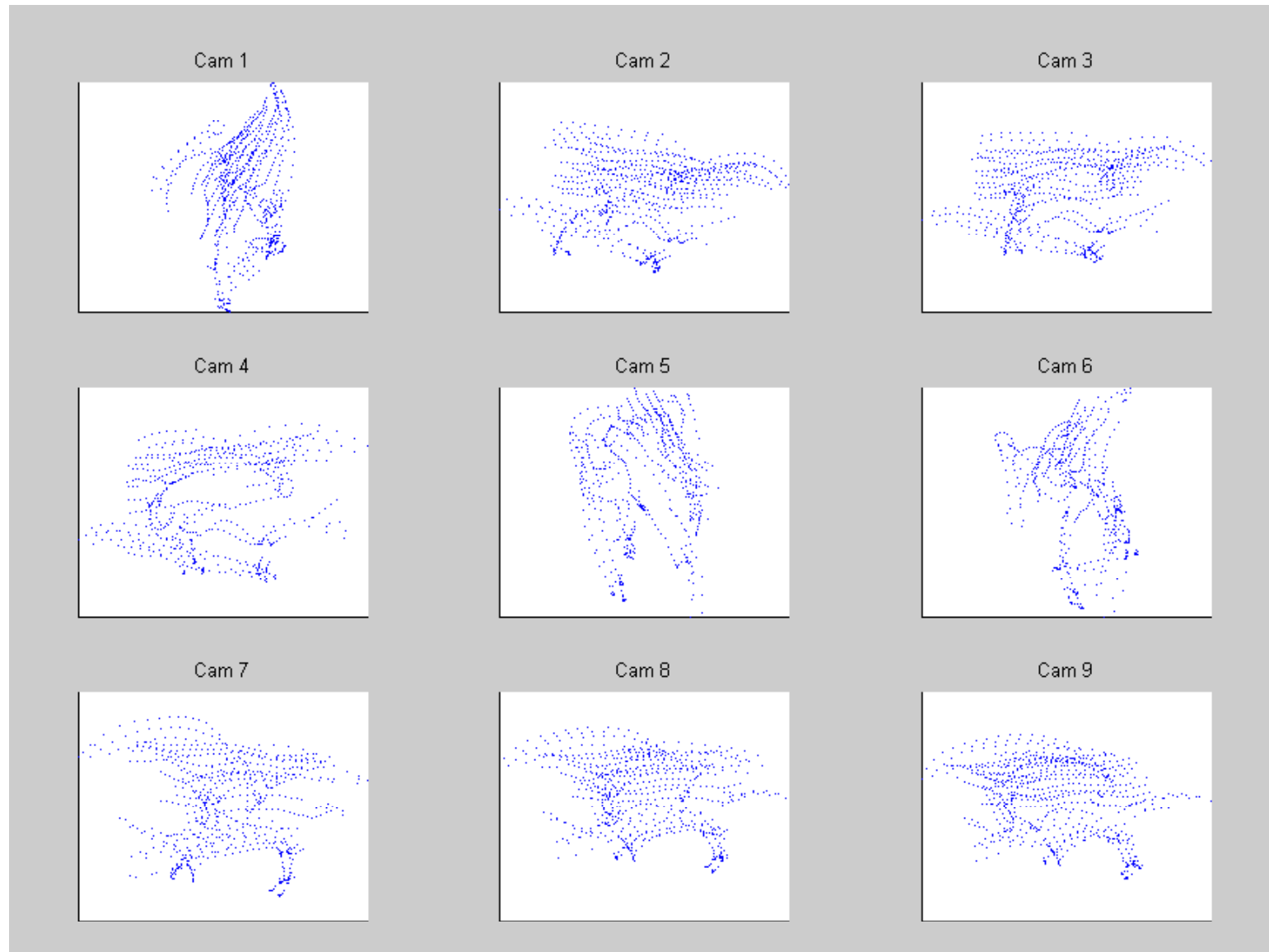



# 1) Creation of 2D strings

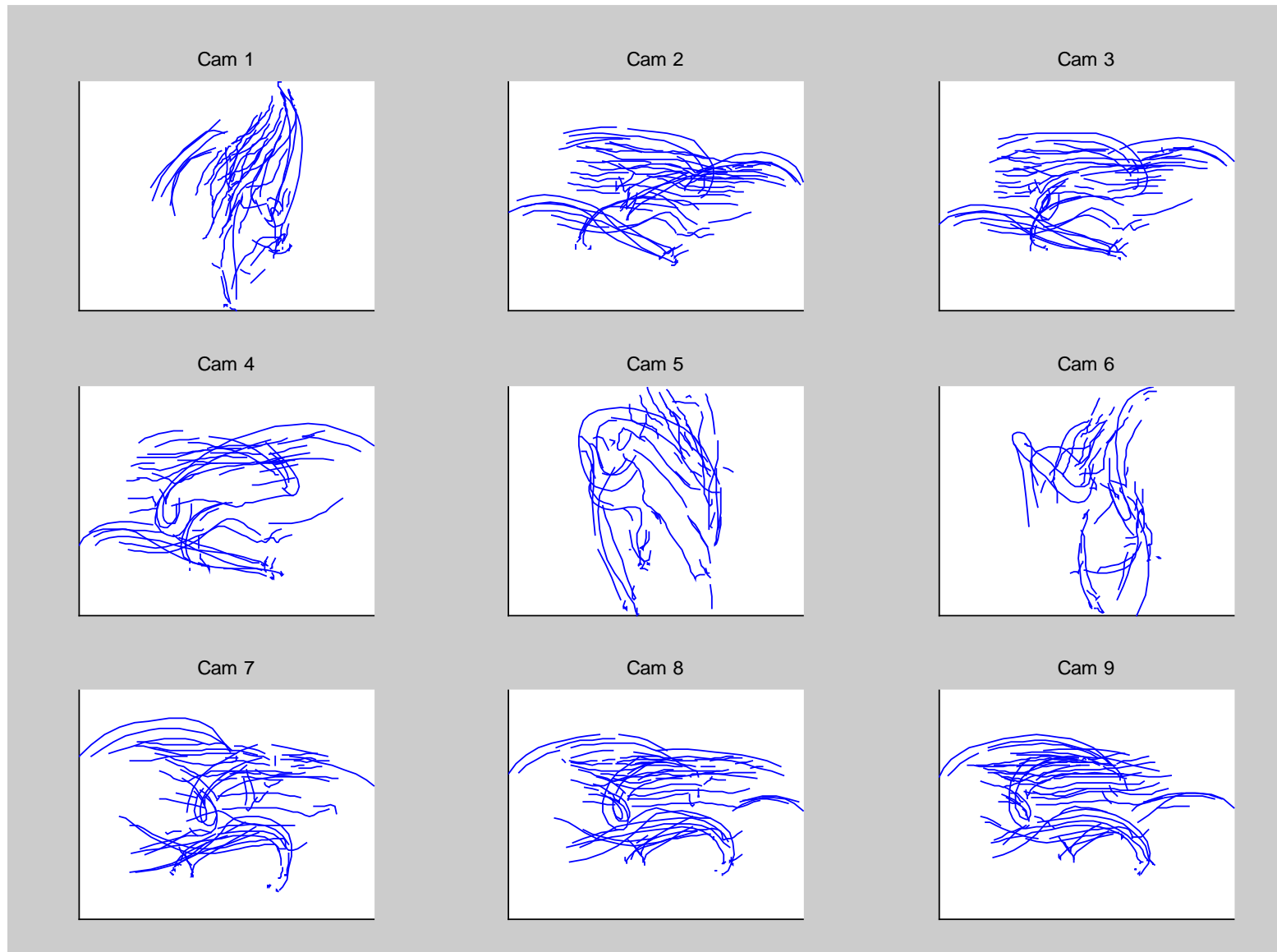



## 2) Matching 2D strings



Epipolarity constraint

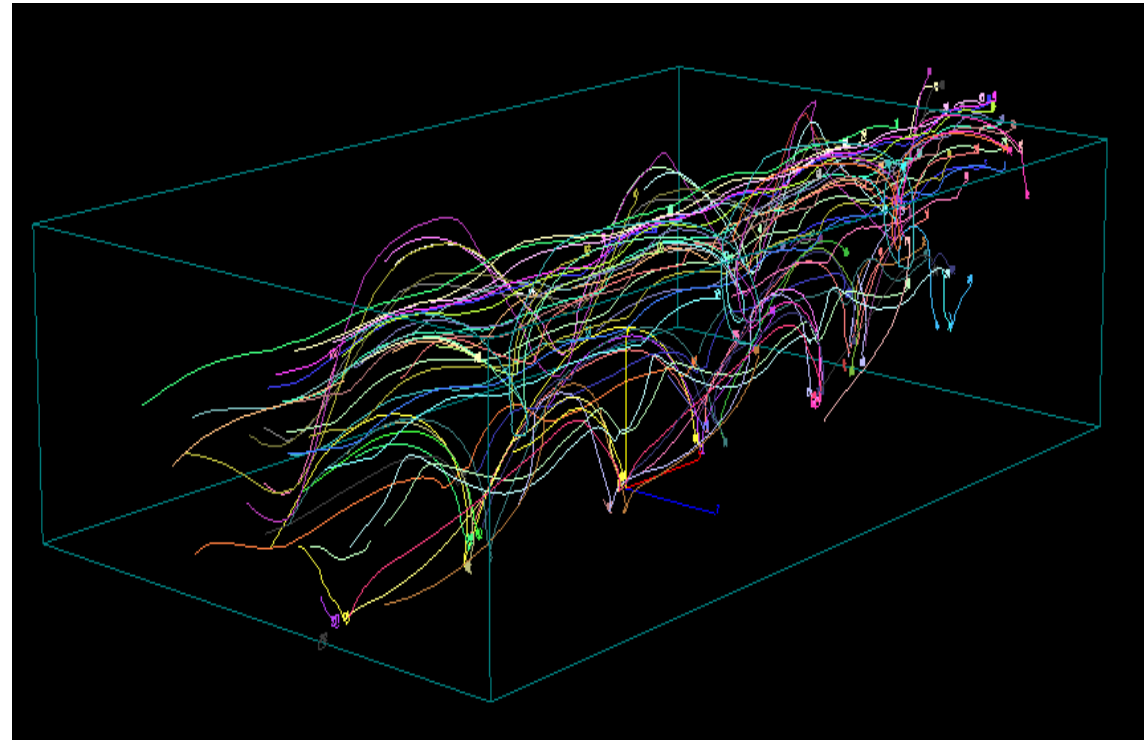
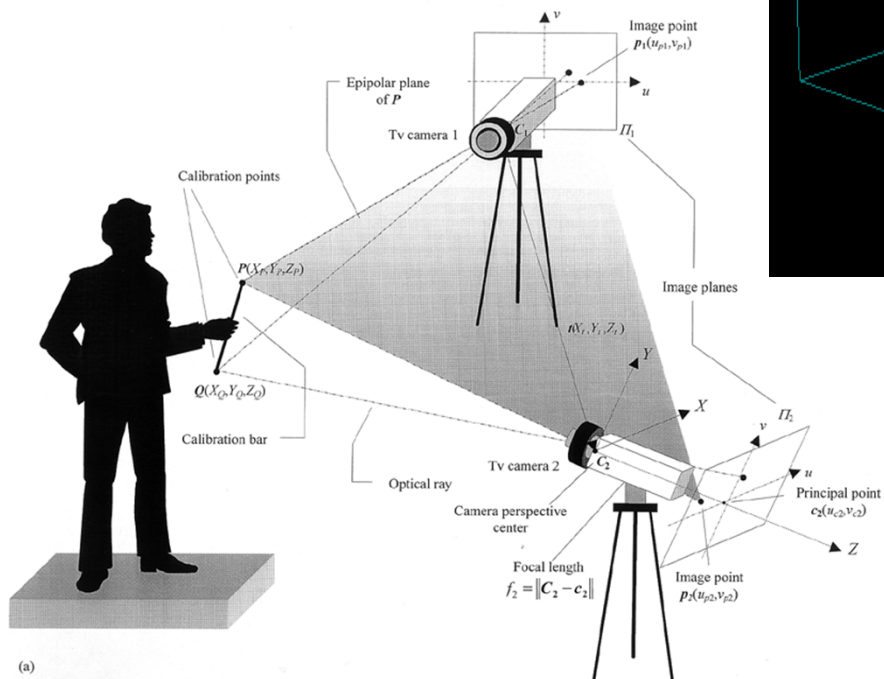

3D strings





### 3) Condensation of 3D strings

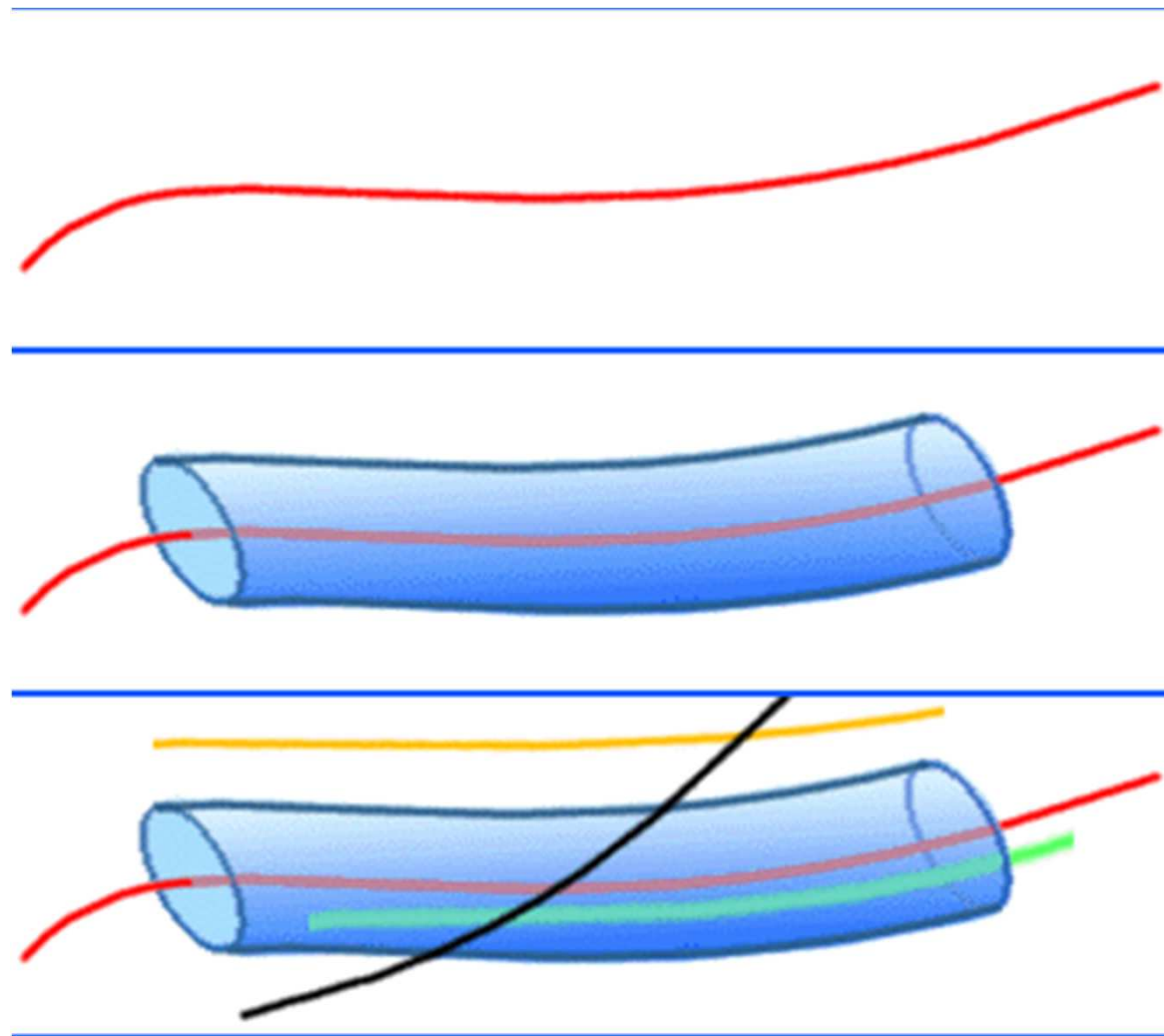



# 4) Joining 3D strings

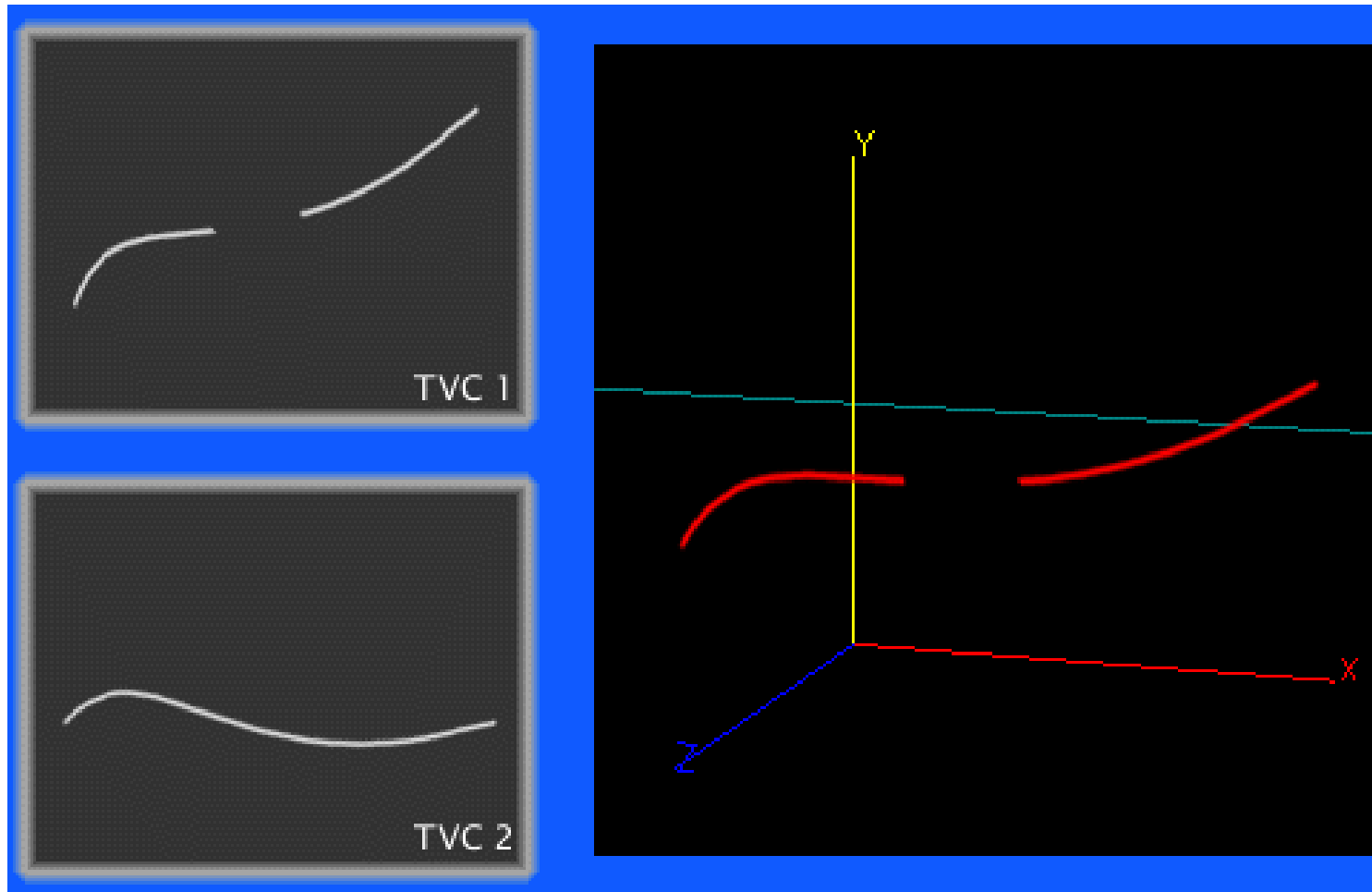



# 3D strings

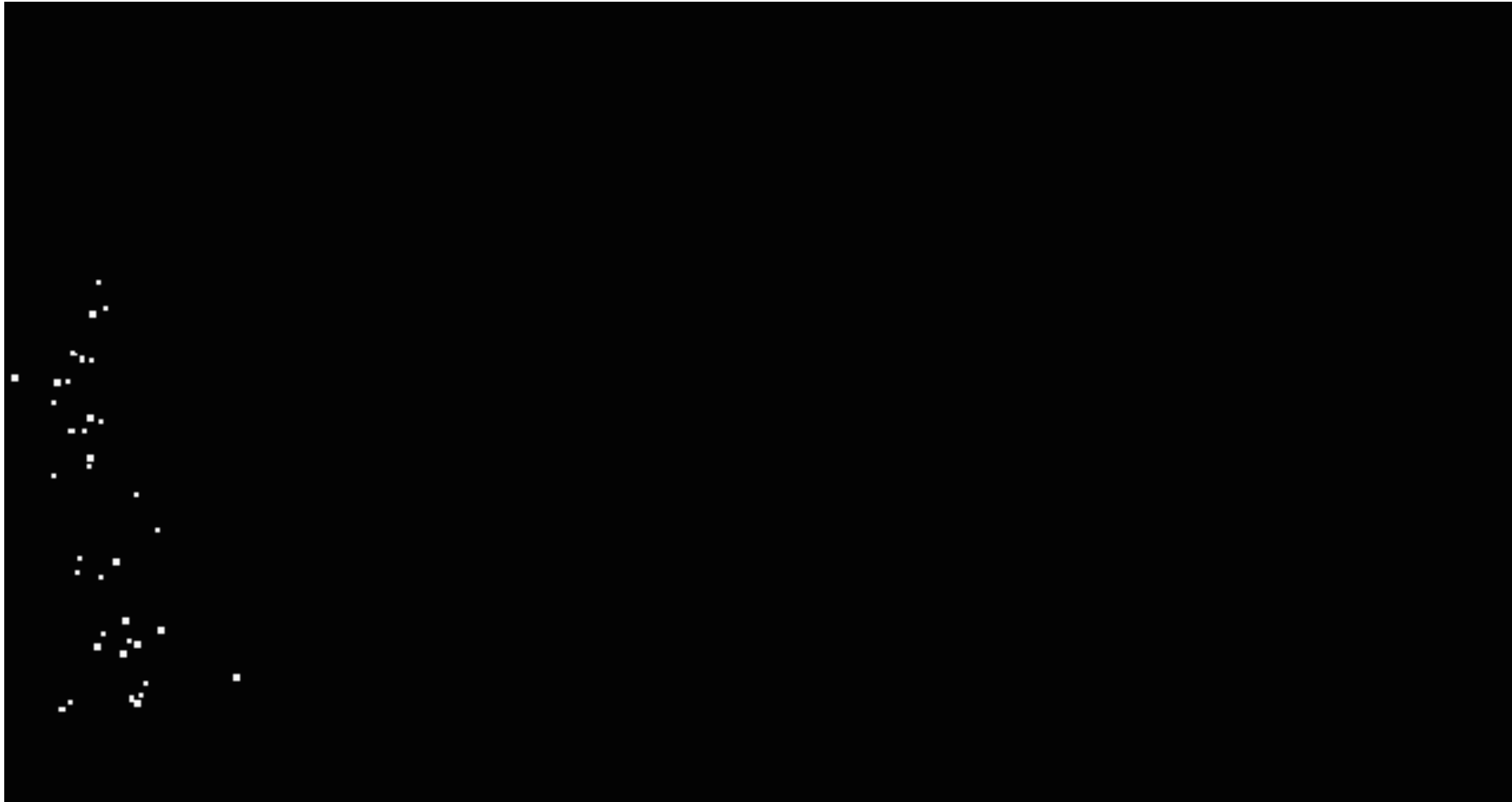

3D strings already contain motion 3D information



# 3D strings

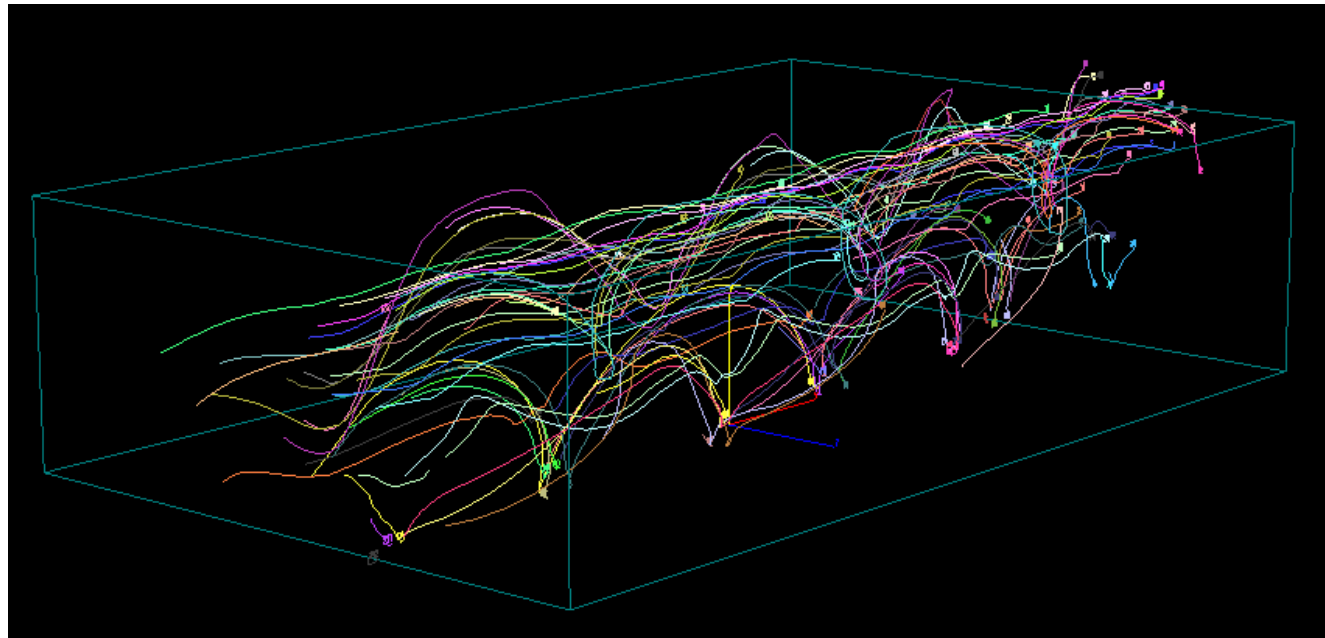
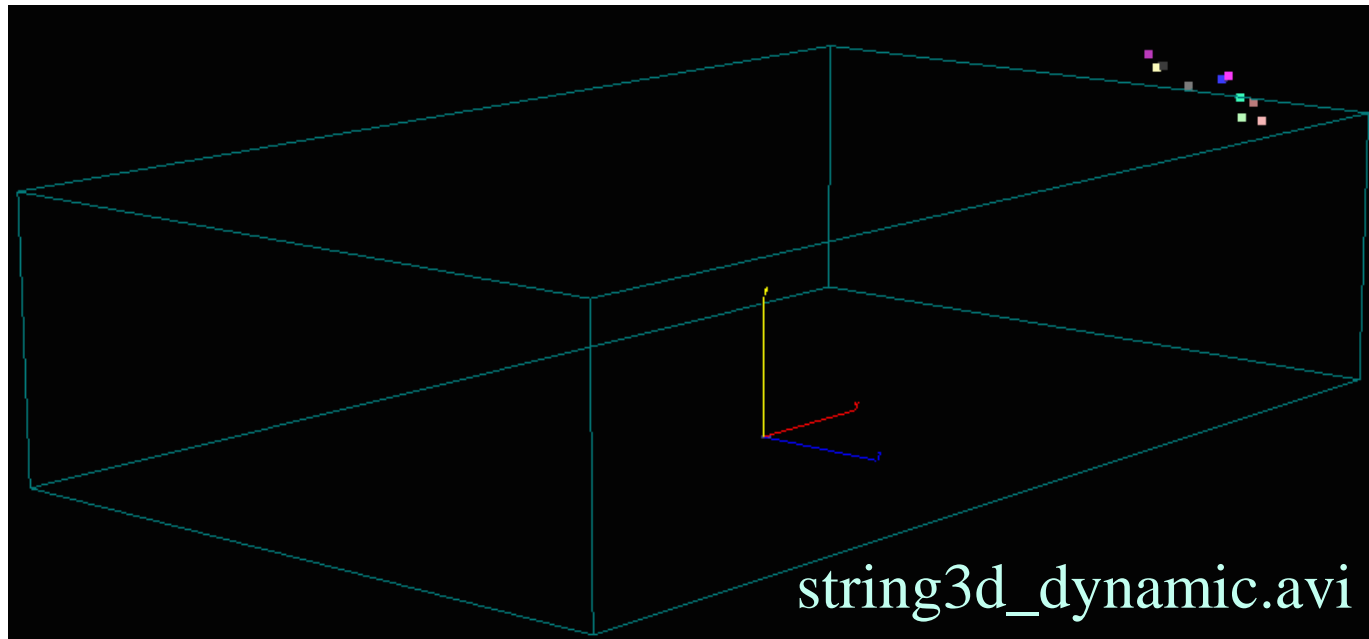



# Model fitting

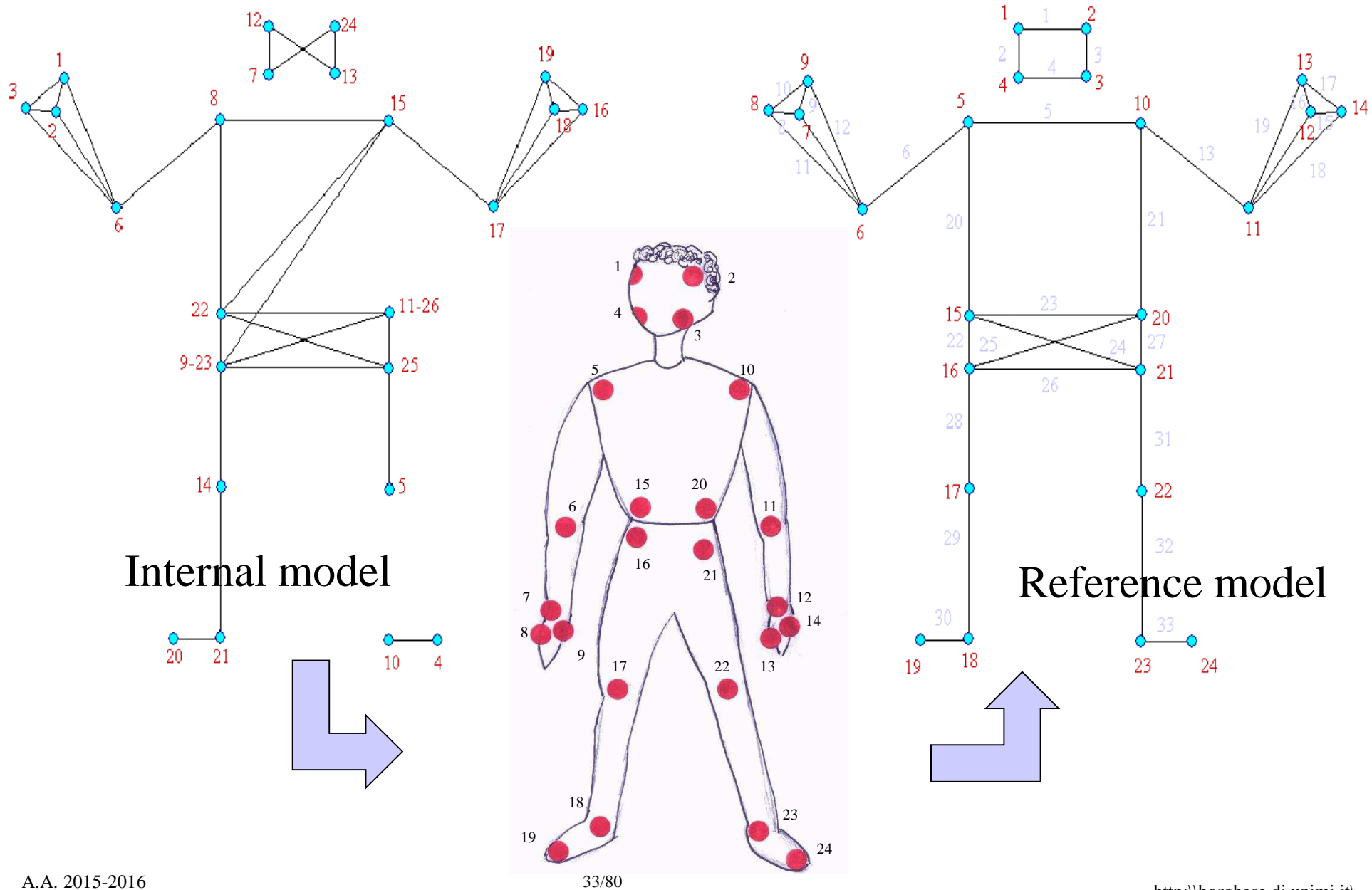

# What a model represents?

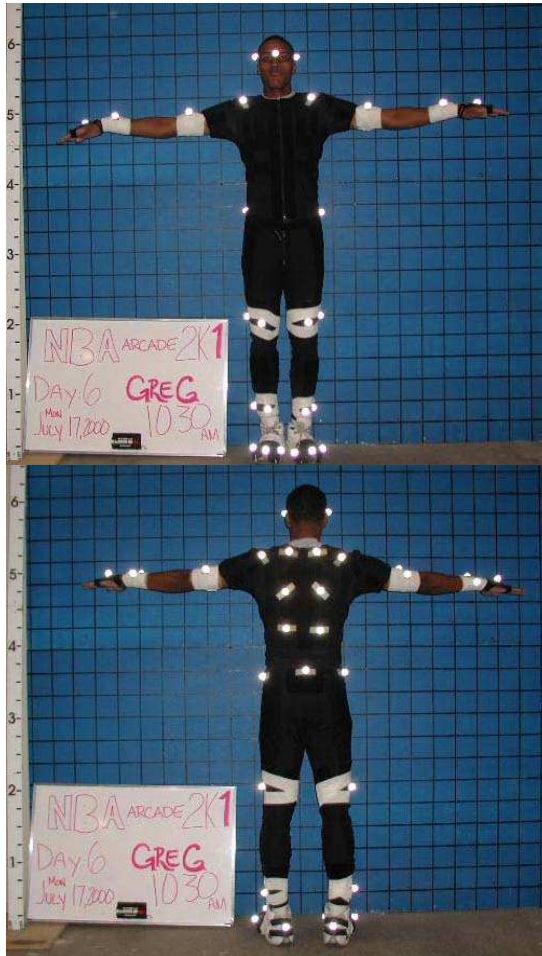

Markered subject

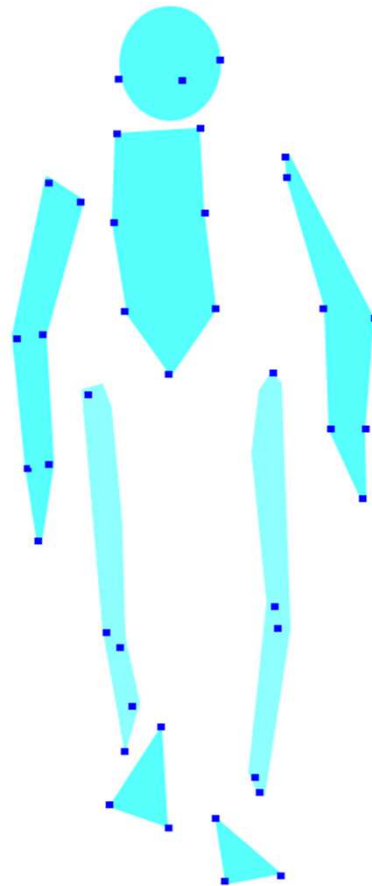

Modello 3D

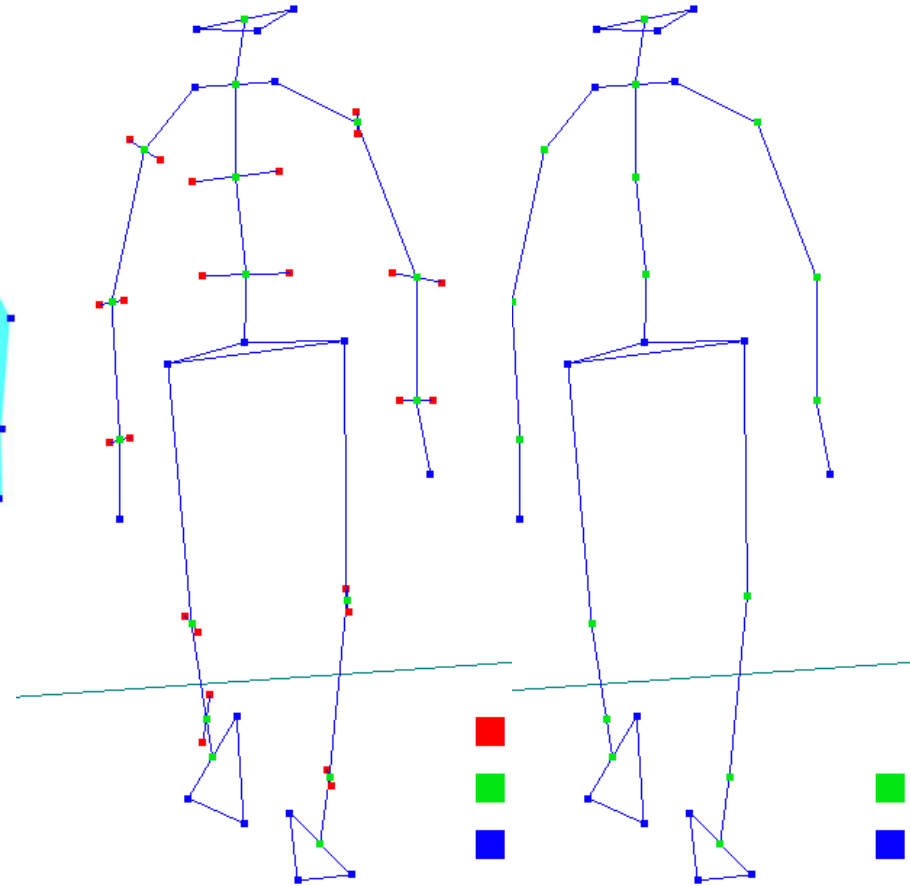

Modello a stick

Modello hidden





# Problems intrinsic in body tracking



- Joints are points inside the body, markers are attached on the body surface.
- Joint are not fixed points: two adjacent bones rotate and slide.
- Joint are not spherical.
- Joints can be complex (e.g. Shoulder, spine)
- Skin artifacts.



# The human skeleton has complex articulations



“Rigid” bones connected. Tendons keep the bones in place.

Motion allowed can be very complex (e.g. shoulder, spine).

The reconstruction of the finest details of the motion are beyond reach, simplifying assumptions are made => ***Level of detail*** in motion analysis

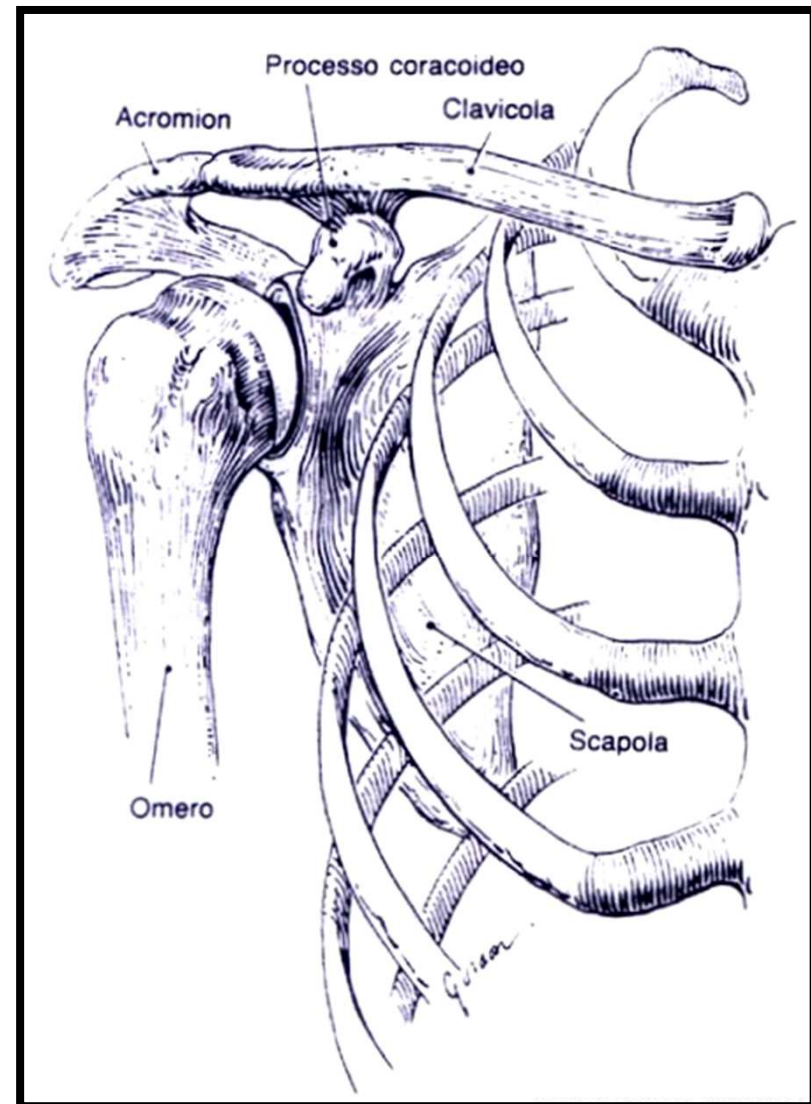



# Video by Superfluo



superfluo3.wmv



# Risultati: escape

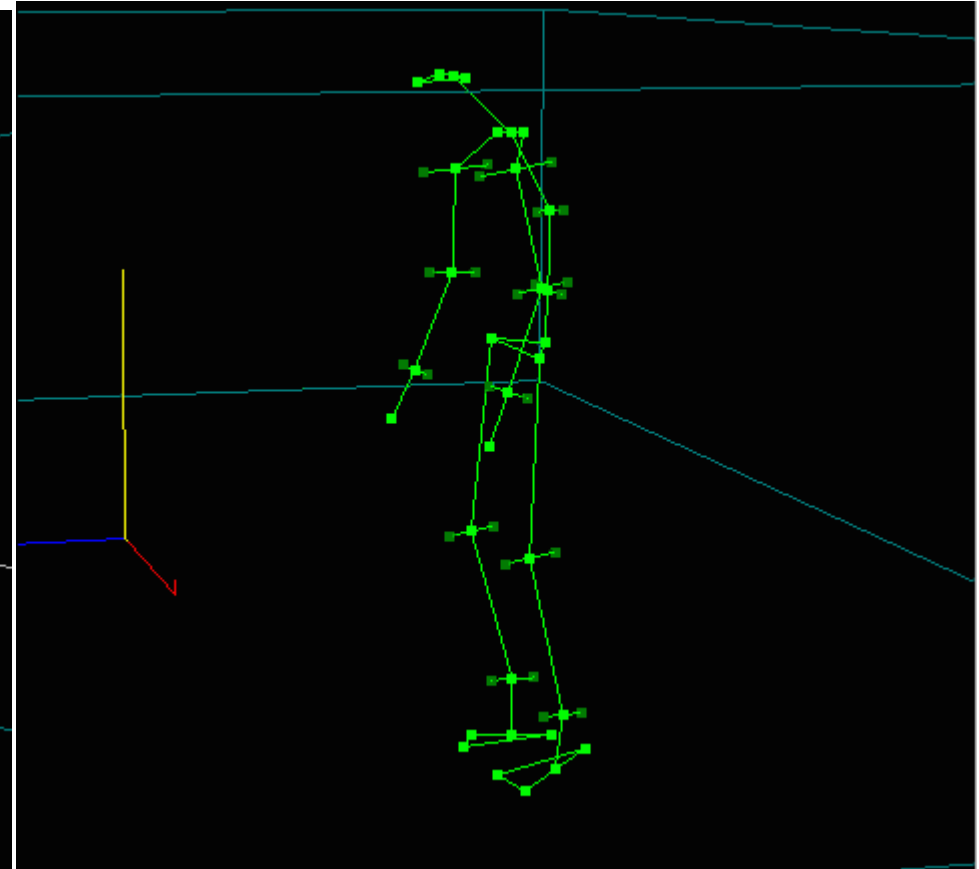
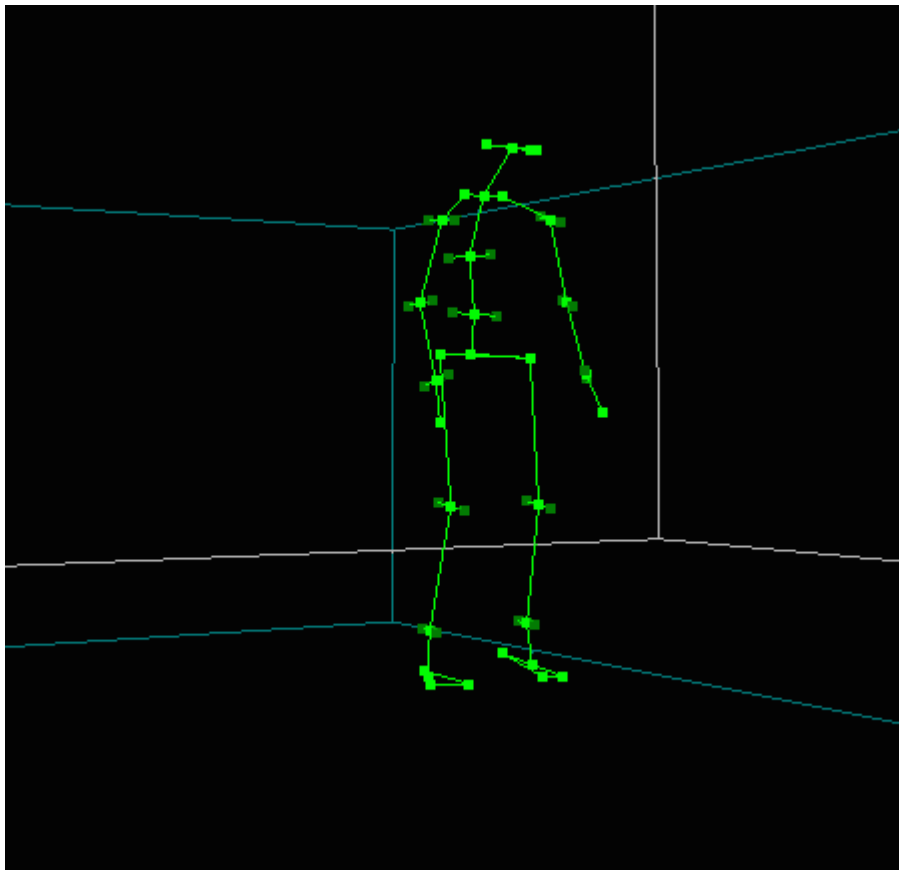



# Risultati: fall\_run

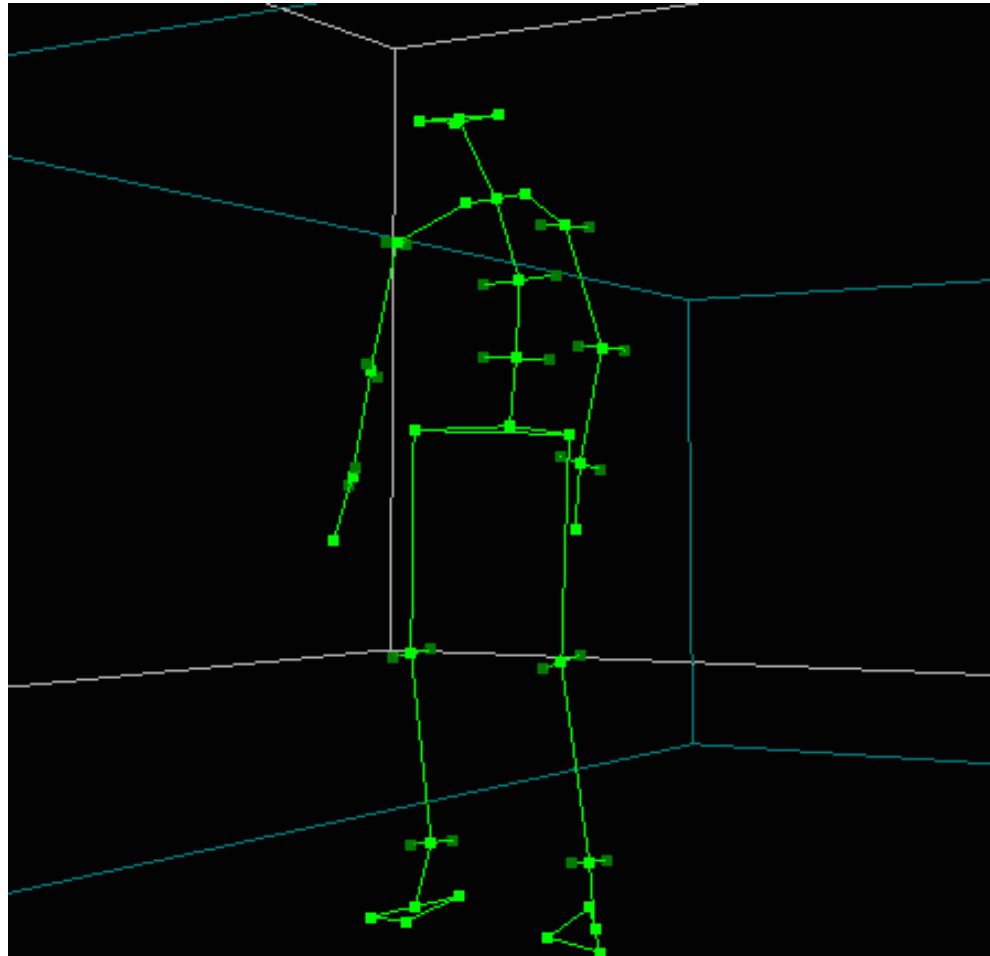



# Risultati: roll

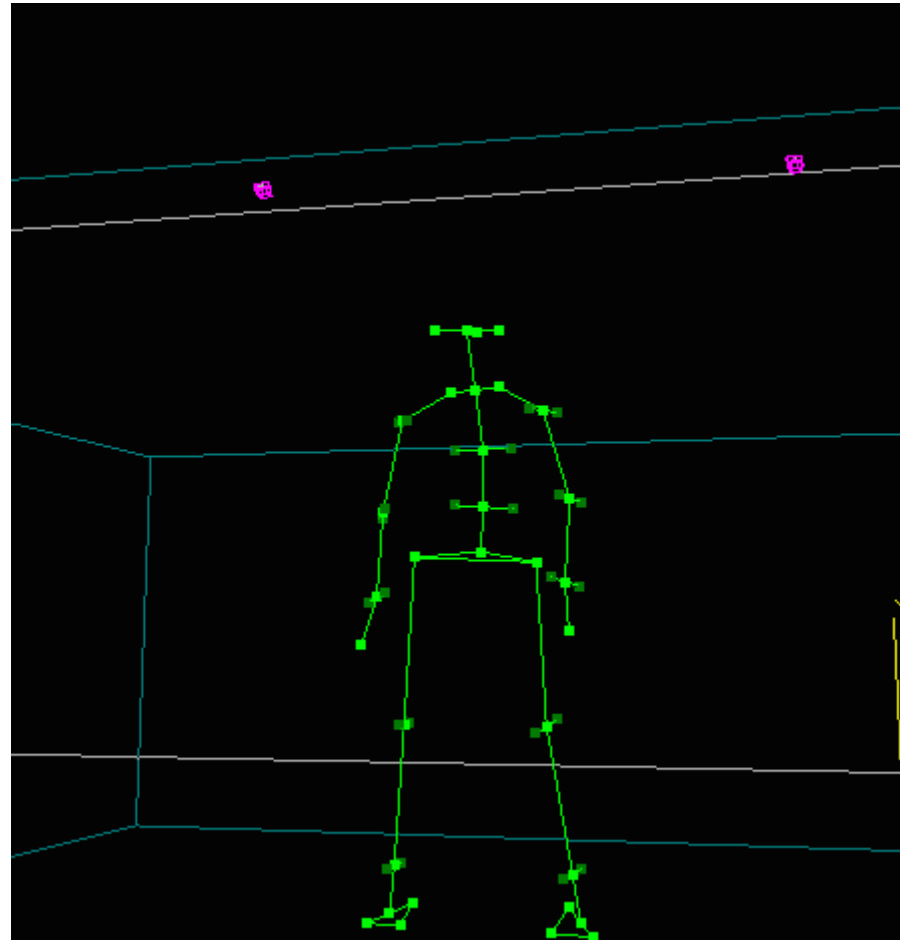



# High jump – top athletes

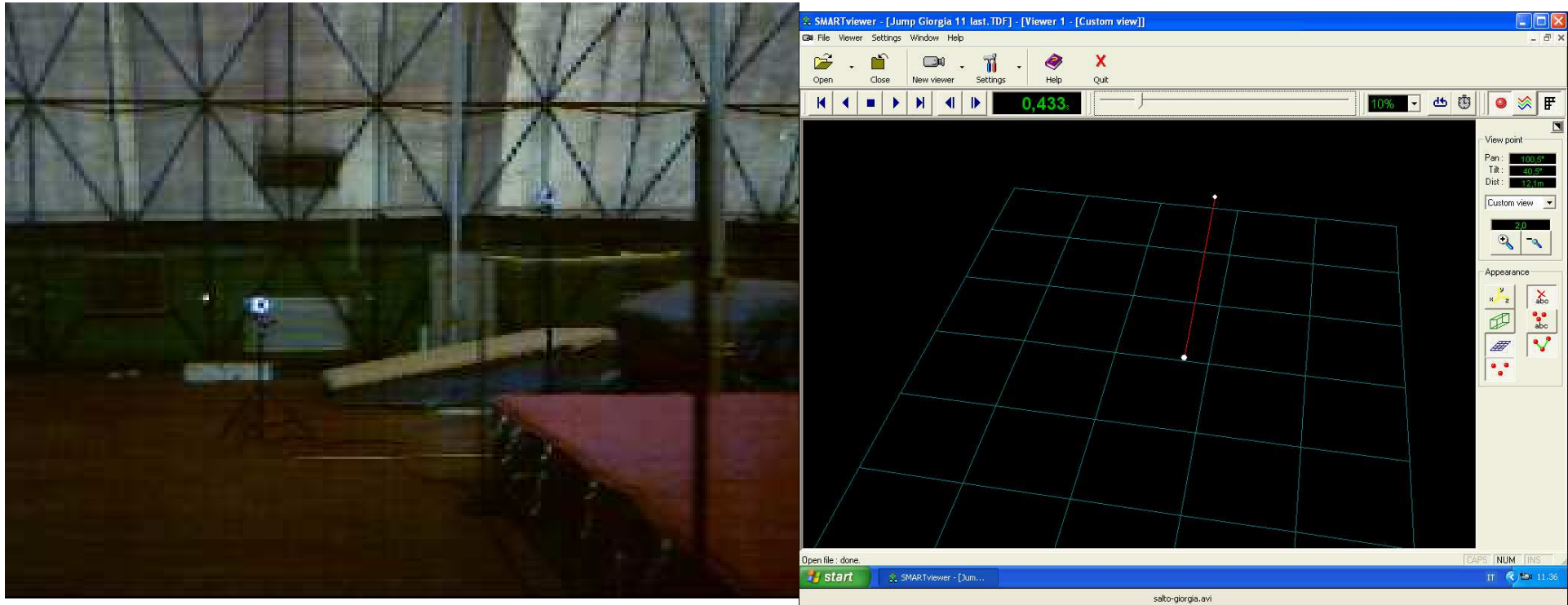





# Can we work without markers?



**Edward Muybridge 1878-1901**

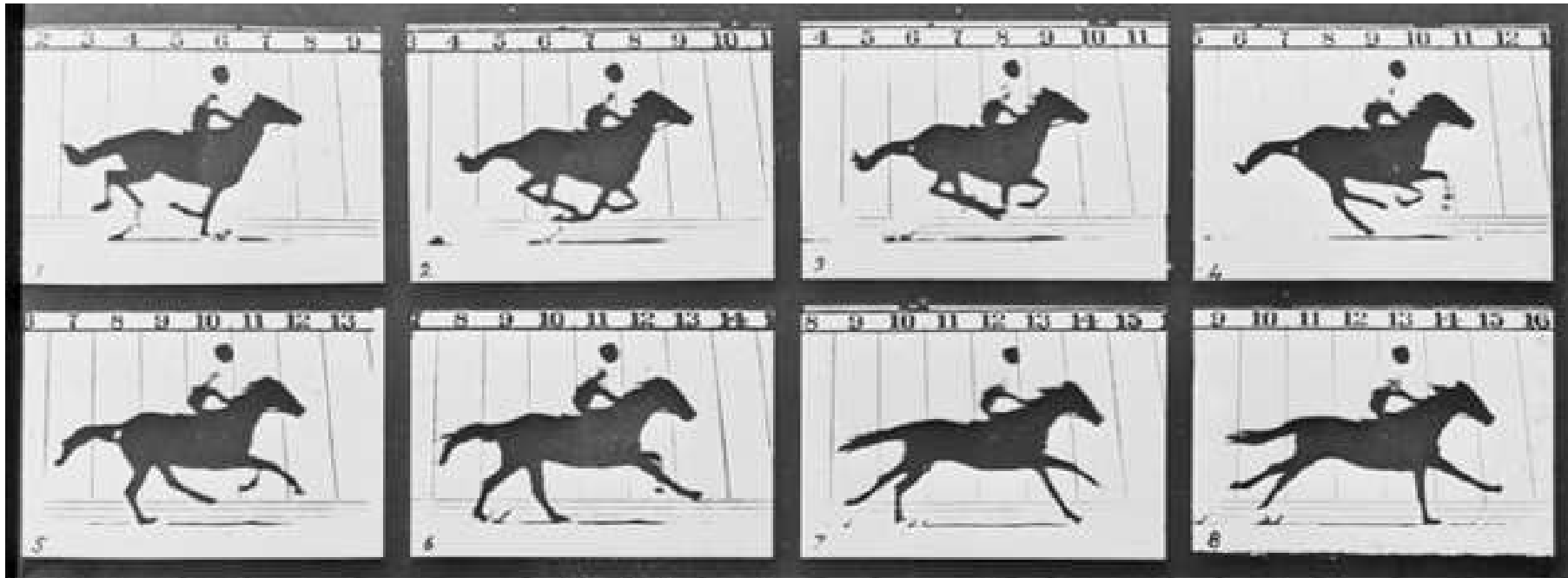

<http://www.edwardmuybridge.co.uk/>



# Edward Muybridge 1878-1901

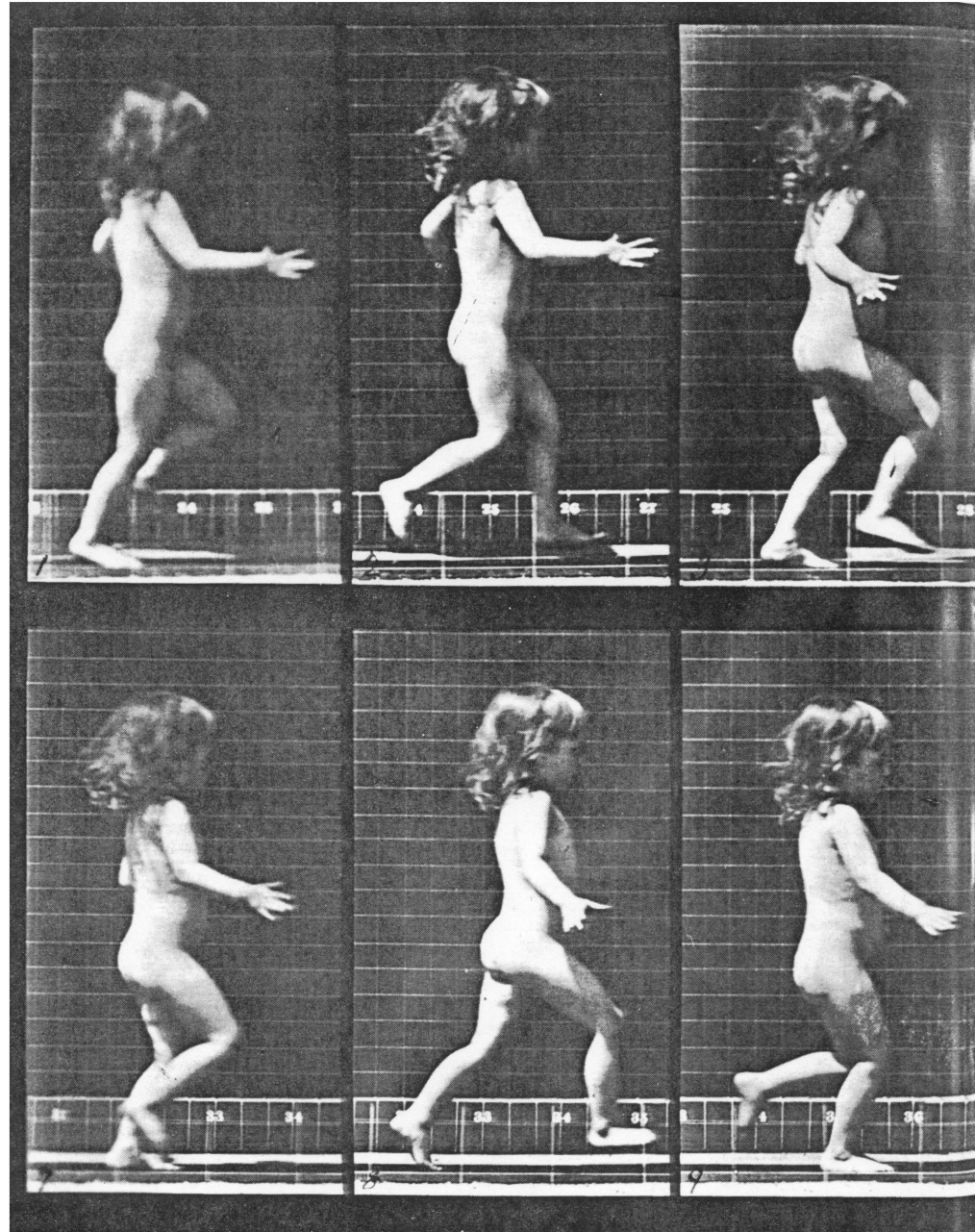



# Computer vision techniques



Silhouette (-> Skeleton)

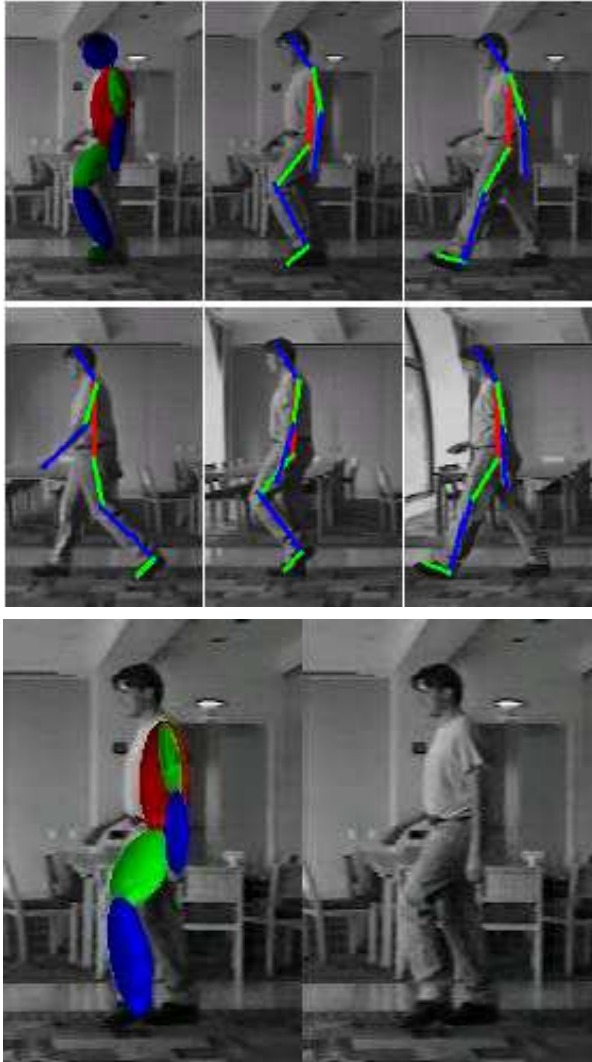

*Set of difficult problems:*

2D Image processing (silhouette identification, optical flow detectors...)

Multi-view invariants.

Smooth motion -> temporal filtering.

Skeleton fitting (different rigid motion for different segments).

**3D cameras help a lot**

<http://movement.stanford.edu/>



# Results: stepping (640 x 480, 10Hz)

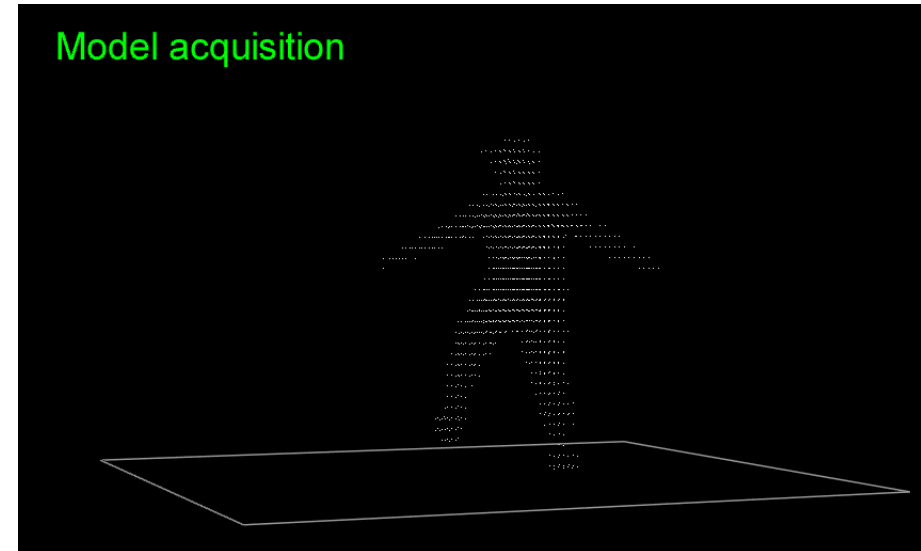

Mikic, Trivedi, Hunter

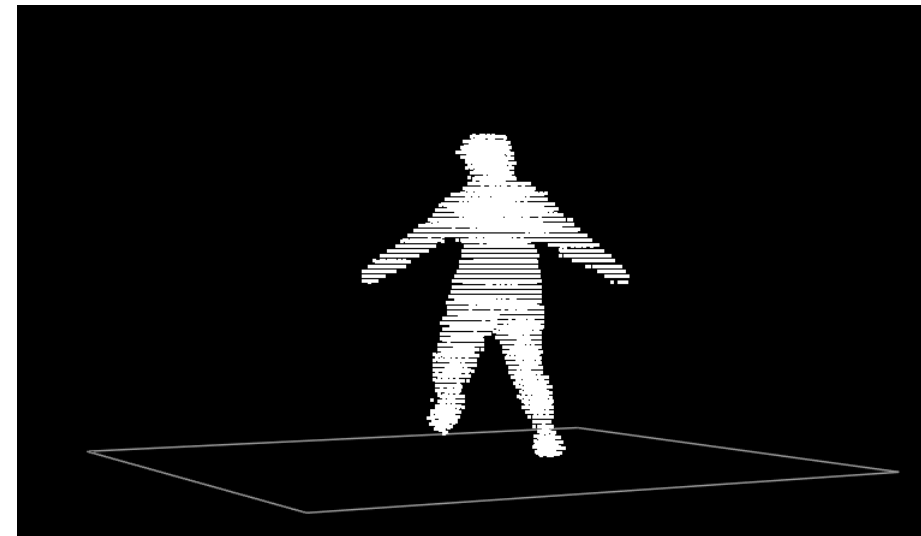





# Results: cartwheel

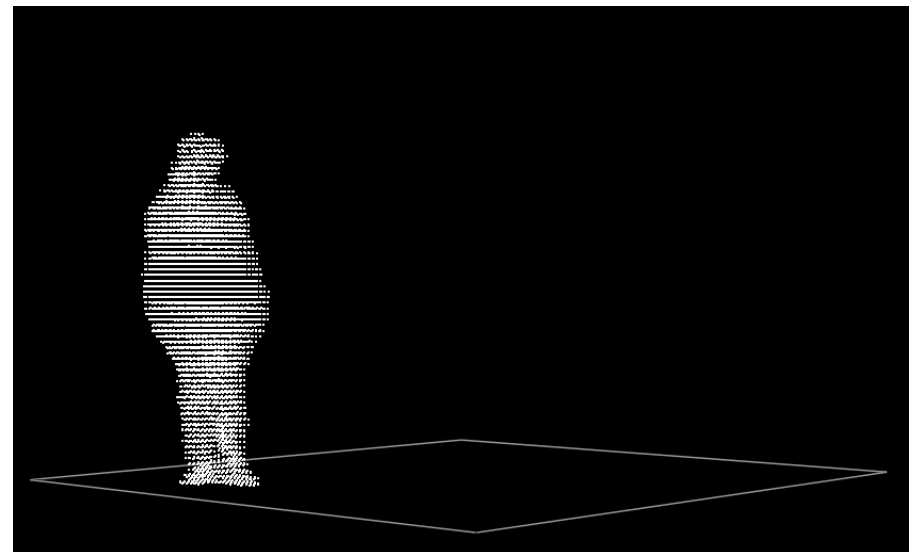
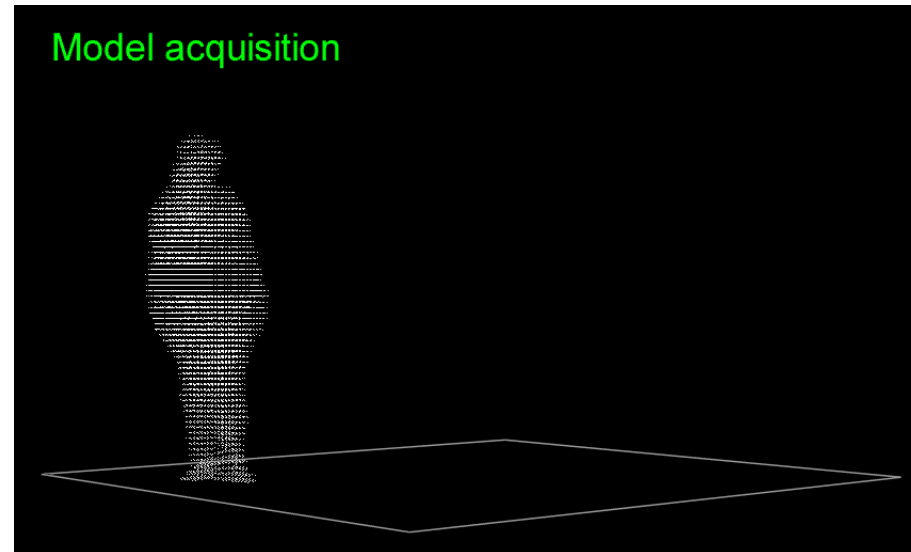



# Body motion from footage (Structure from Motion)

2 approcci:

- Probabilistico. Stima di un modello parametrizzato e dei parametri di movimento.
- Deterministico. Definisco un modello a-priori e stimo i parametri della camera e del movimento.





## 2D color coded tracking

- Players could interact with a 3D scene by moving known brightly saturated colored objects that were visually tracked in PlayStation 2 (EyeToy Webcam). Threshold on color representation.
- Pose recovery can be accomplished robustly for certain shapes of known physical dimensions by measuring the statistical properties of the shape's 2D projection. In this manner, for a sphere the 3D position can be recovered (but no orientation), and for a cylinder, the 3D position and a portion of the orientation can be recovered.

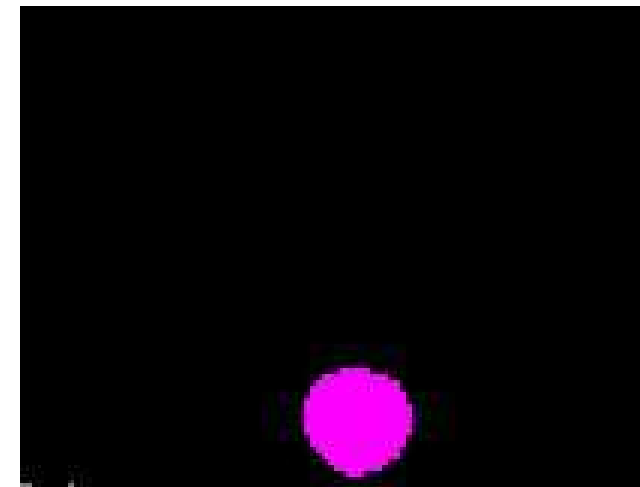

- Multiple objects can be also be combined for complete 3D pose recovery, though occlusion issues arise.
- Perfect recognition in all lighting conditions is difficult.





# 2D collision detection

- Collision detection with target can be checked by analyzing the overlapping between part of the motion mask only in particular regions.
- Identification of the motion mask as the outermost part of the body. Approximated collision detection defining general shapes.

Correct Hand collision area  
(most left pixel in the area around first top most high pixel)

- Collision with targets gives hit, collision with distractors gives a miss.
- Same principles implemented with Sony EyeToy Webcam (2003).

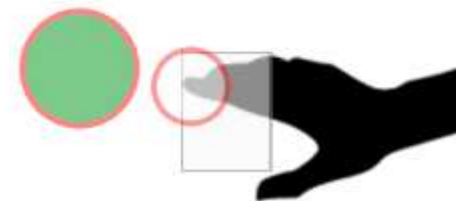



# Markerless optical motion capture



- Clustering and labeling of each image with a probabilistic framework.
- Addition of temporal and spatial constraints.
- Special stage place is required.
- Cost and complexity

[www.organicmotion.com](http://www.organicmotion.com)





# 2D tracking for rehabilitation

Duck-neglect project <http://borghese.dsi.unimi.it/Research/LinesResearch/Virtual/Virtual.html>

”Magic mirror” paradigm in which video of the player is overlaid with graphics generated by the computer.



Background measurement. Thresholding.

In this case, silhouette is tracked.

Alternative is the difference between consecutive images (glaring and blurring require some filtering).

[duckNeglect\\_video\\_v0.mov](#)



# La camera come strumento di ripresa

Come si forma un'immagine?

- Scena con oggetti riflettenti.
- Sorgente di illuminazione
- Piano di rilevazione della luce riflessa.



Il motore di questa trasformazione è la **proiezione prospettica**.

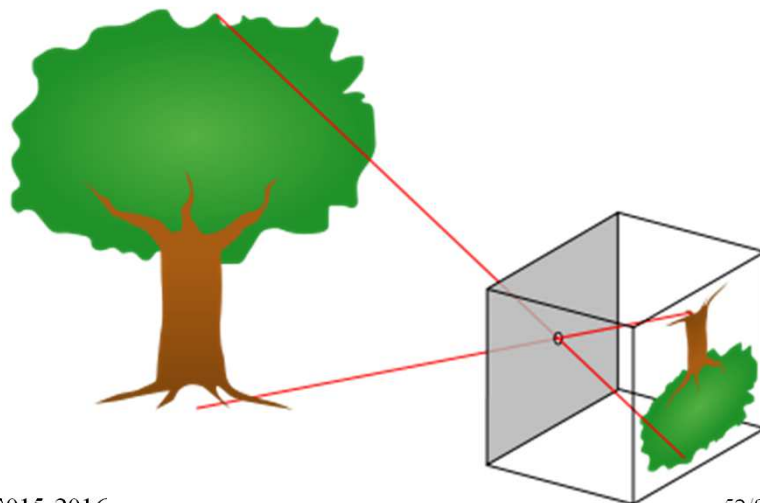

Modello pin-hole

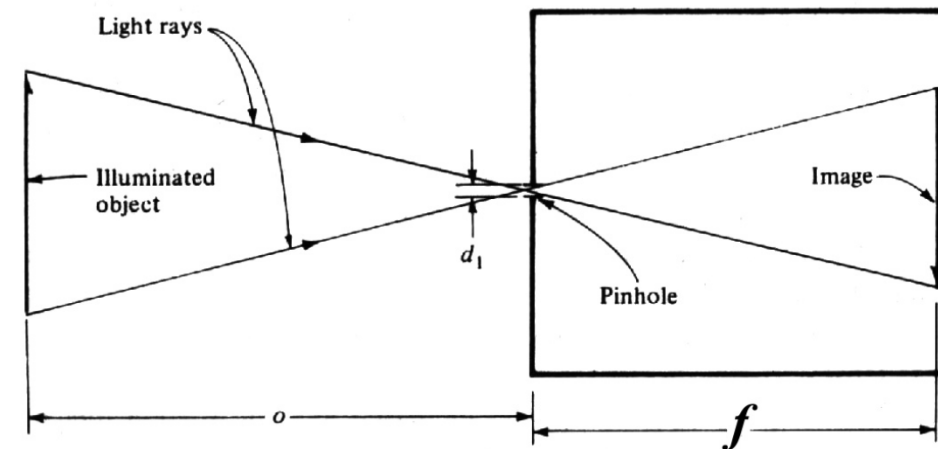



# La pin-hole camera

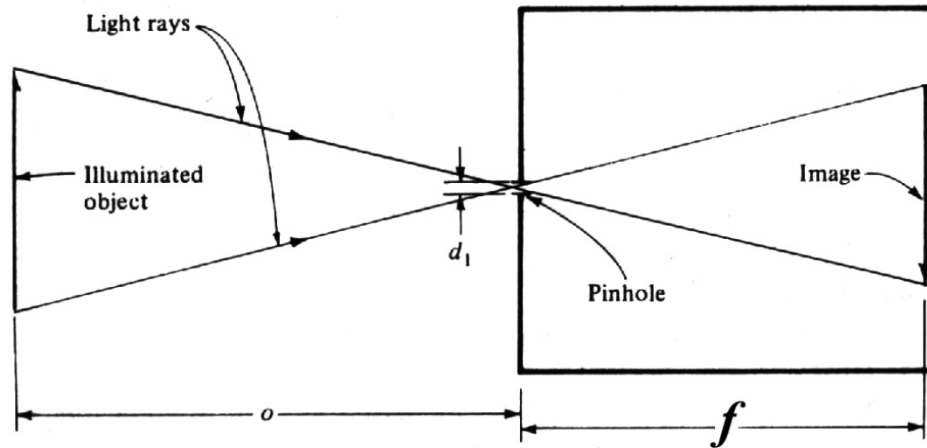

**Proiezione prospettica:**  
tutti i raggi di proiezione  
passano per un unico punto,  
detto **centro di proiezione**.

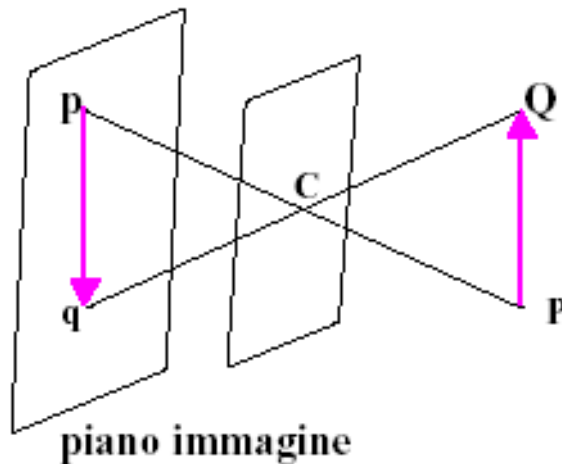

Pinhole camera



# La lente

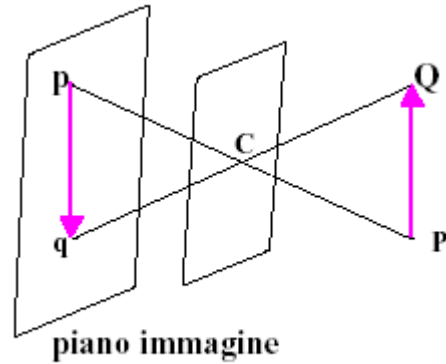

Pinhole camera

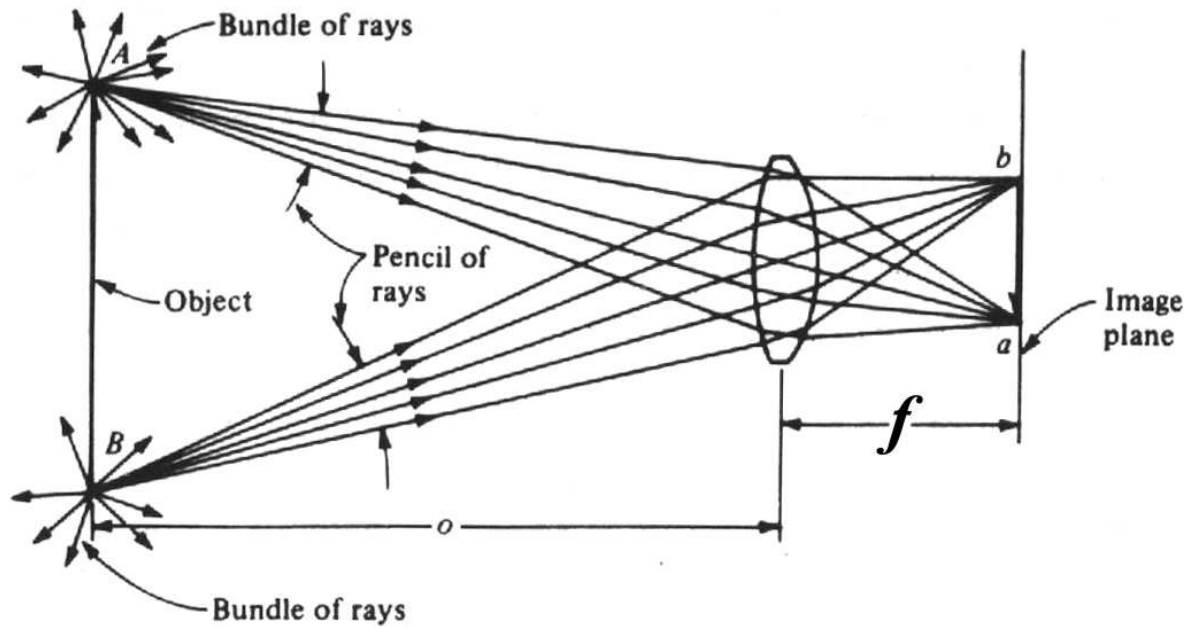

Lente convergente





# Geometria dell'ottica

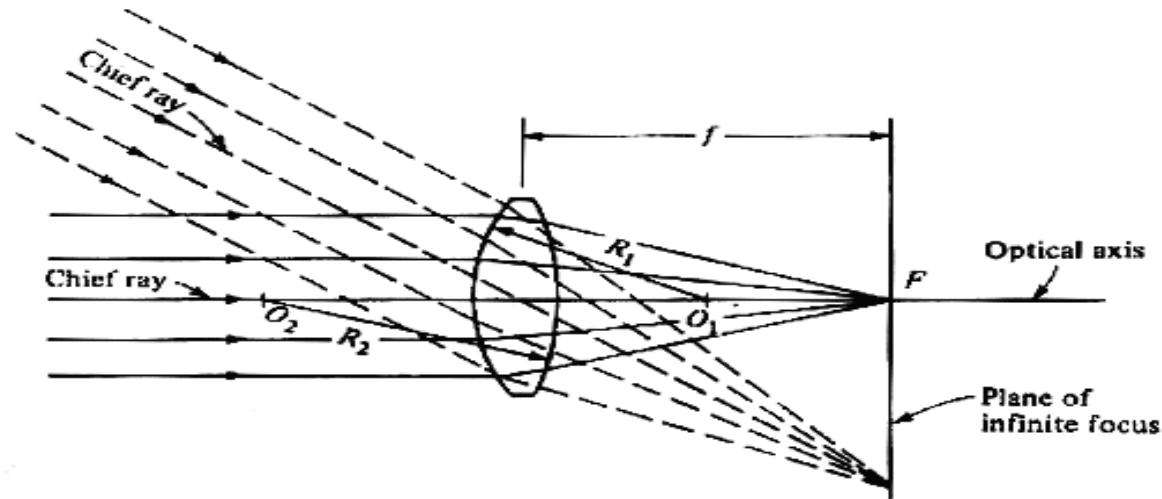

Oggetti all'infinito

- **Distanza focale**: distanza del piano immagine quando un oggetto si trova all'infinito.
- **Asse ottico**: raggio che non viene deviato dalla lente.
- Intersezione dell'asse ottico con il piano immagine dà il **punto principale (F)**.



# Messa a fuoco



## Problema della messa a fuoco

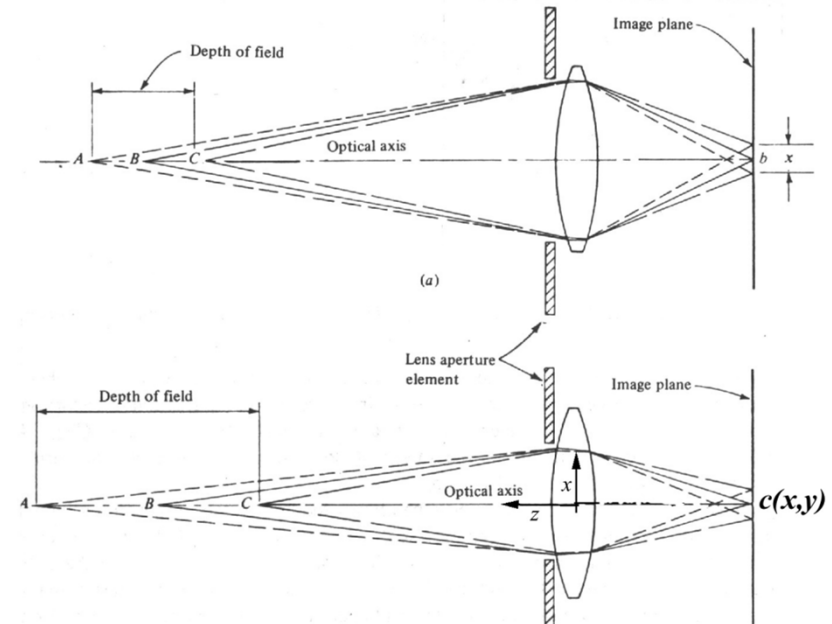

### Parametri di camera (o intrinseci):

- Punto principale  $c(x,y)$  + lunghezza focale,  $f$  (3 parametri).
- Occorre conoscere anche il fattore di forma dei pixel nel caso di immagini digitali (è una costante, non un parametro).
- (Distorsioni).



# L'occhio umano

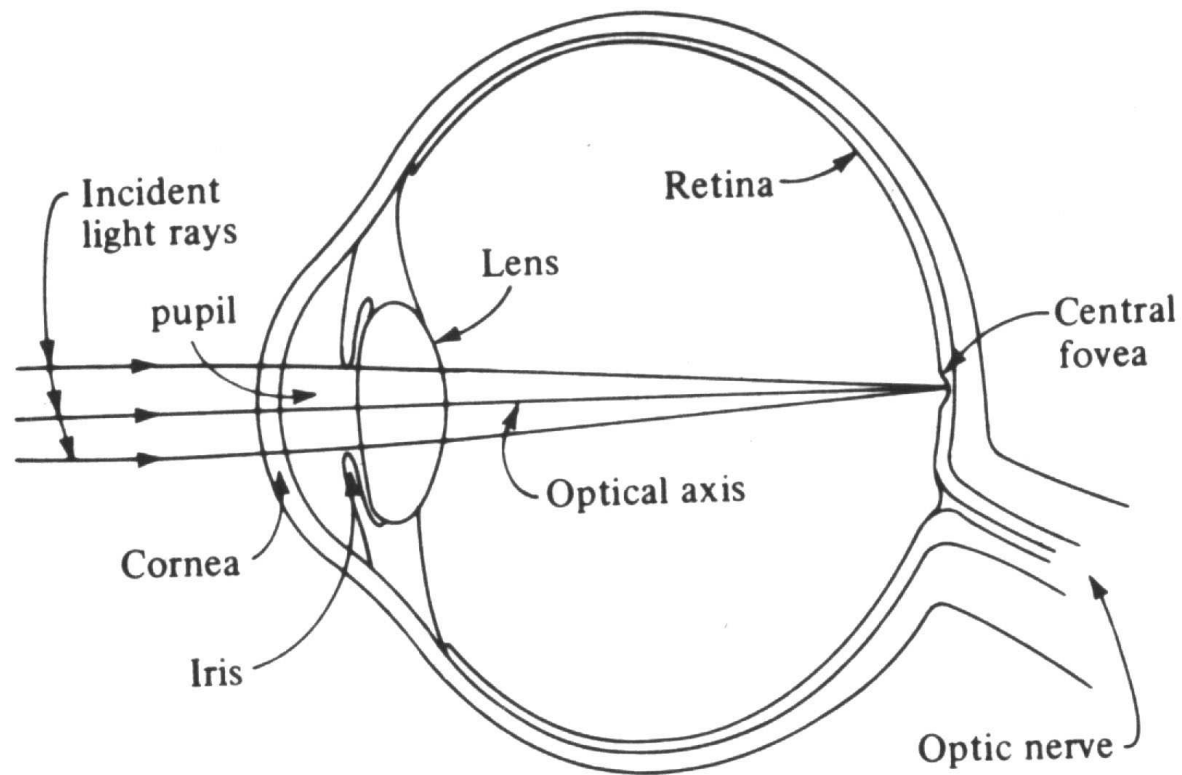

Its behavior is very similar to that of a camera



## 2.5D cameras (Kinect)



- 3D scanner with active pattern (IR)
- RGB camera
- Robust background separation
- Robust skeletal tracking

**Used as a Web-cam with advanced silhouette subtraction for rehabilitation.**

**Come to our lab and see...**

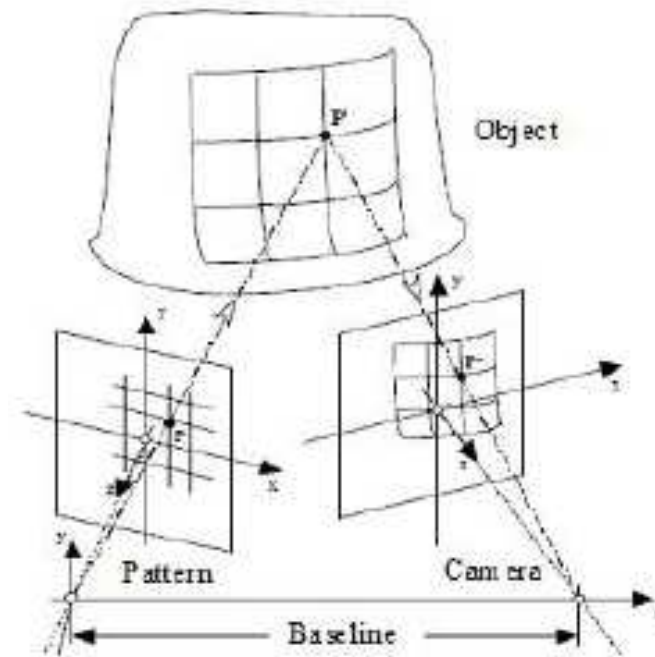



## 2.5D First SDK for Kinect

Primesense drivers, with skeleton tracking: <http://www.primesense.com/se.com>

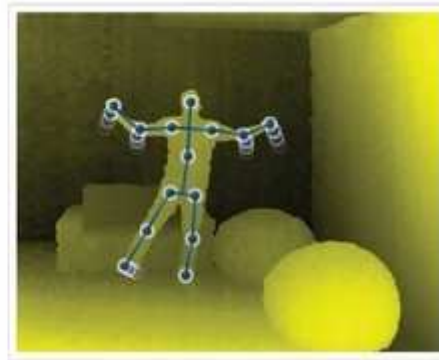

Color (RGB) Image



Depth Image



Audio Stream

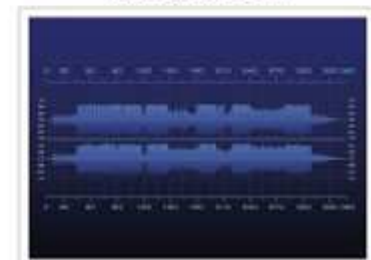

**Open Source drivers:**

<http://openni.org>

[http://openkinect.org/wiki/Main\\_Page](http://openkinect.org/wiki/Main_Page)

Microsoft's SDK is available



# Calibration is a pre-requisite

## Camera calibration

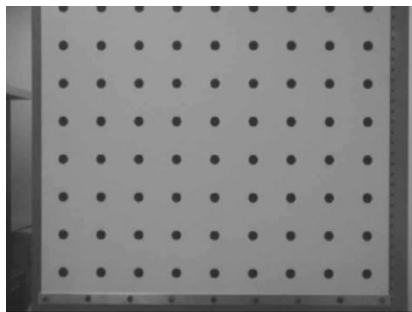
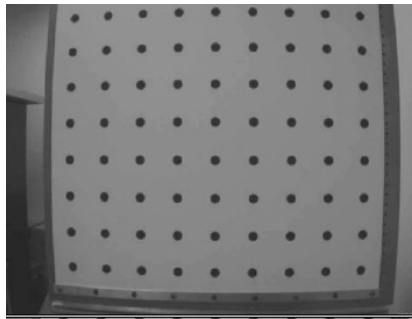

Set-up calibration

Excellent for special effects, not so good for measurements....  
Cameras are not metric.





# Inertial tracking::Wii

$$\text{pitch} = \arctan\left(\frac{a_z}{a_y}\right)$$
$$\text{roll} = \arctan\left(\frac{a_z}{a_x}\right)$$

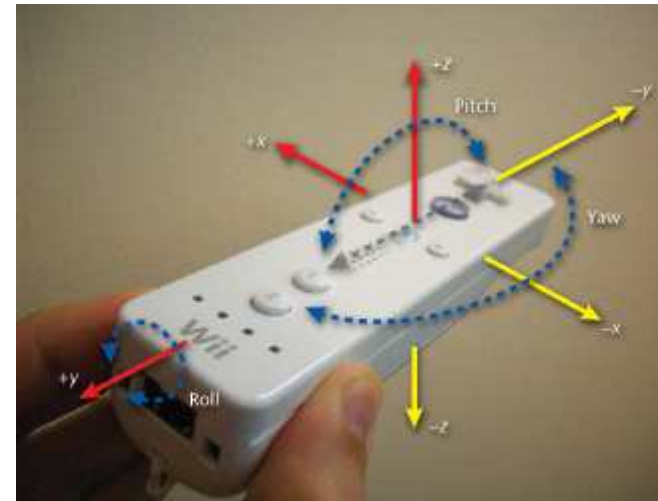

Positional data are obtained through integration.

⇒Instability. A flip of the LSB for one frame generates a rotation at constant speed!!

Other devices are required to stabilize the measurements: Nunchuk (gyroscope), sensor IR-bar





# Inertial tracking::Xsens

- Xsens by Moven is a full-body, camera-less inertial motion capture (MoCap) solution. It is flexible motion capture system that can be used indoors or outdoors (on-set). With the short turnaround times MVN is a cost effective system with clean and smooth data.
- Costly

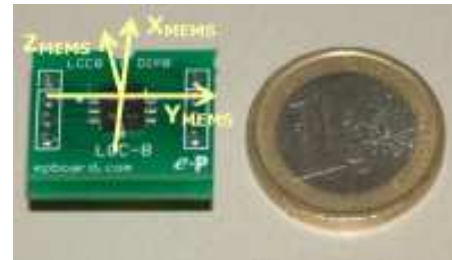

- We have used such system inside the FITREHAB project:

<http://www.innovation4welfare.eu/287/subprojects/fitrehab.html>



# Where are we now (optoelectronic)?



Optotrak, 1991.

LED + cameras



- Measure the position of the joints.
- Time multiplexing for the markers (3 at 450Hz or 750Hz with additional hardware). No-tracking, real-time.
- Power for the LEDs has to be delivered on the subject's body (markers get hot on the skin!!).
- Accuracy 0.1mm (X,Y), 0.15mm (Z, depth).



## Where are we now (magnetic)?

***Magnetic technology: Fastrack & older Polhemus sensors.***

They measure: pitch, yaw and roll; X, Y, Z of the segments.

Electro-magnetic induction.



The transmitter is a triad of electromagnetic coils, enclosed in a plastic shell, that emits the magnetic fields. The transmitter is the system's reference frame for receiver measurements.

The receiver is a small triad of electromagnetic coils, enclosed in a plastic shell, that detects the magnetic fields emitted by the transmitter. The receiver is a lightweight cube whose position and orientation are precisely measured as it is moved.



# Fast-track Motion Capture



- Higher accuracy through oversampling and DSP signal processing (0,5” and 1.8mm accuracy). Range of 75cm for high accuracy.
- Sensitive to ferromagnetic (metallic) objects.

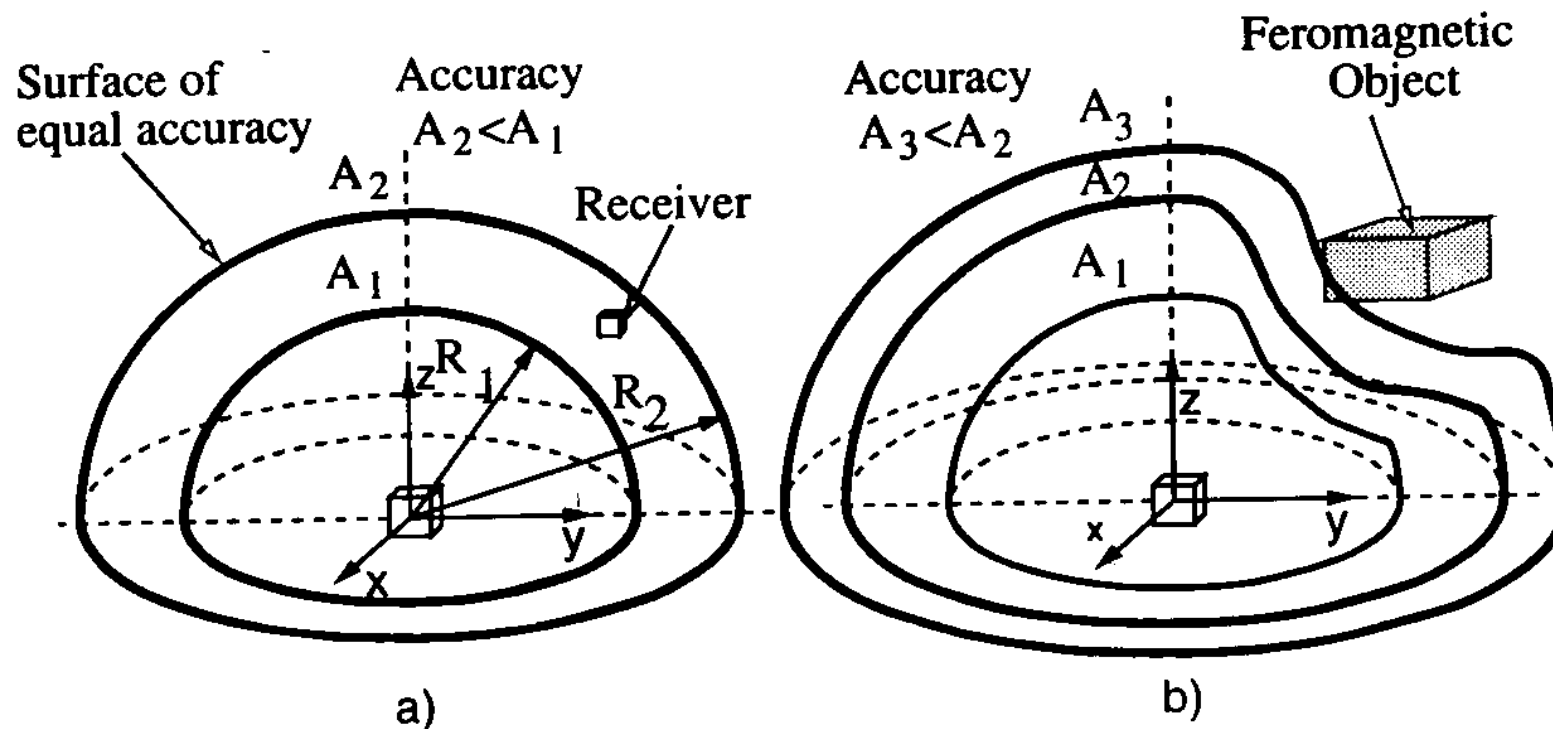

- Latency: 4msec.
- Sampling rate: 120Hz. Rate drop with multiple receivers because of multiplexing.



# Flock of birds Motion Capture

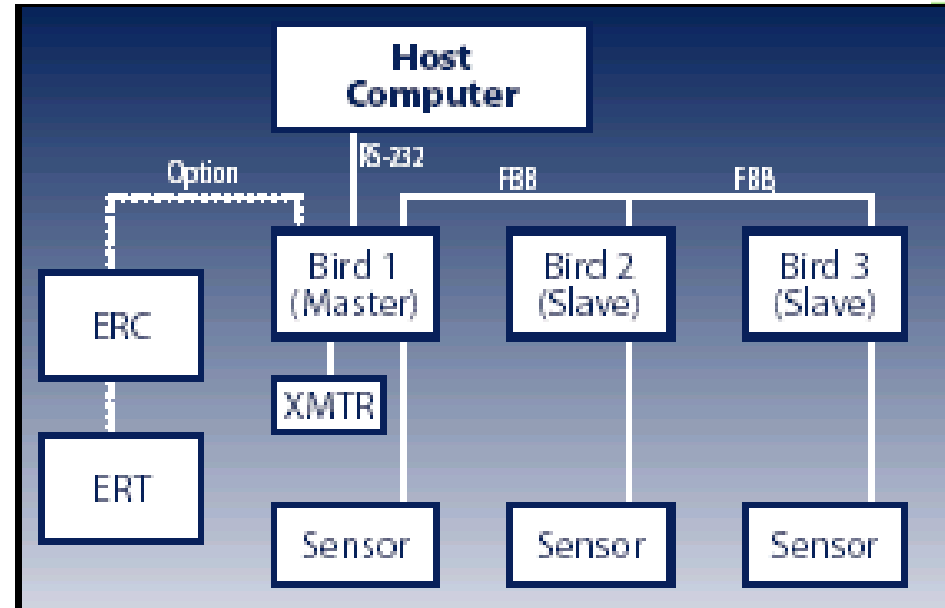

- Each receiver has its own DSP.
- All the DSP are connected with a fast internal bus.
- Latency is increased (8ms).

When more than one transmitter is adopted (experimental):  
larger field (single transmitter at a time)  
higher accuracy (time-slicing)

***Not really un-obtrusive! Low accuracy. Real-time.***



# Gloves



Monitor fingers position and force.

Problems with the motion of the fingers:

- overlap.
- fine movements.
- fast movements.
- rich repertoire.





# Sayre glove (1976)

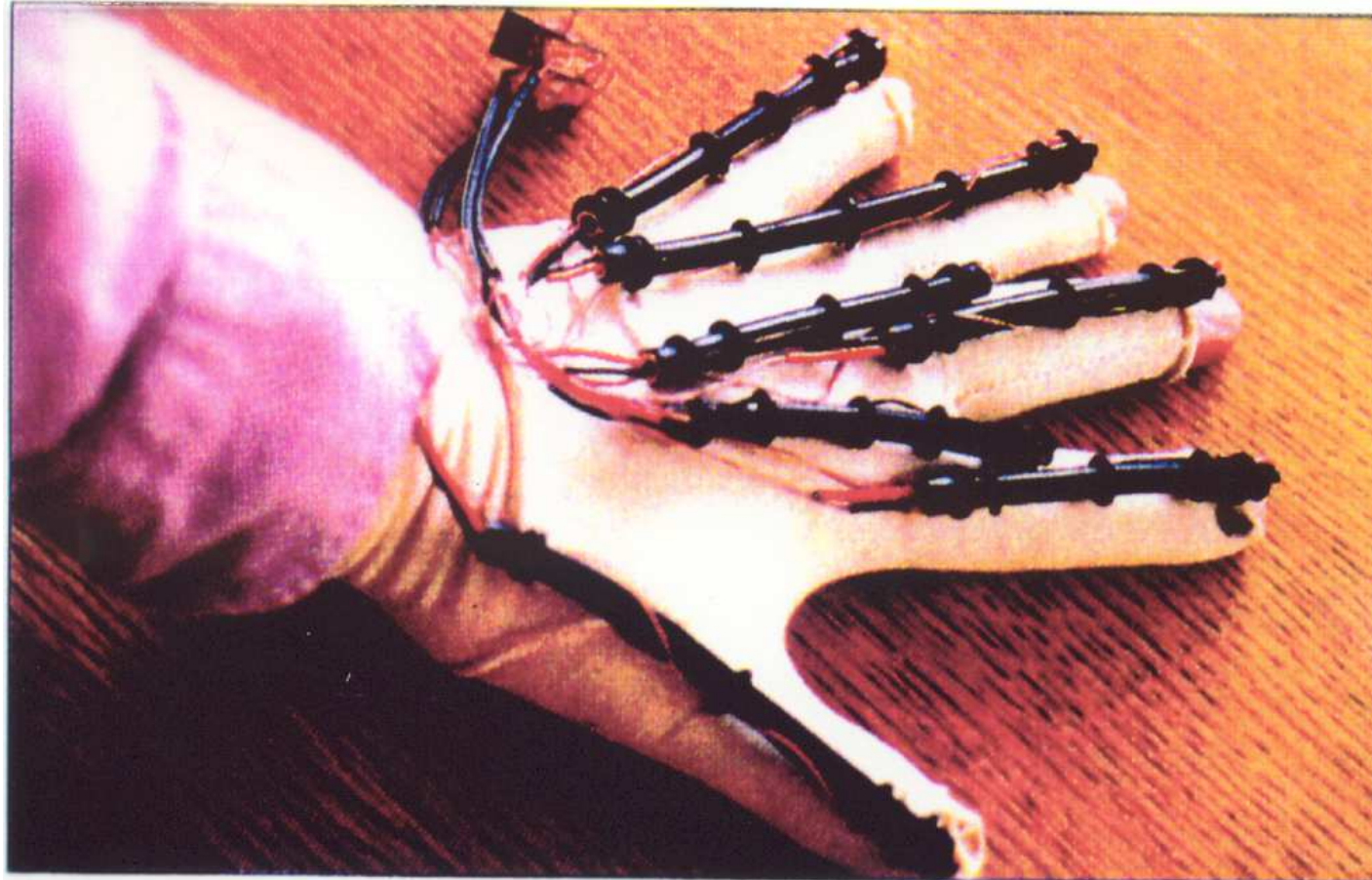



# MIT glove (1977)







# Digital Data Entry Glove (1983)

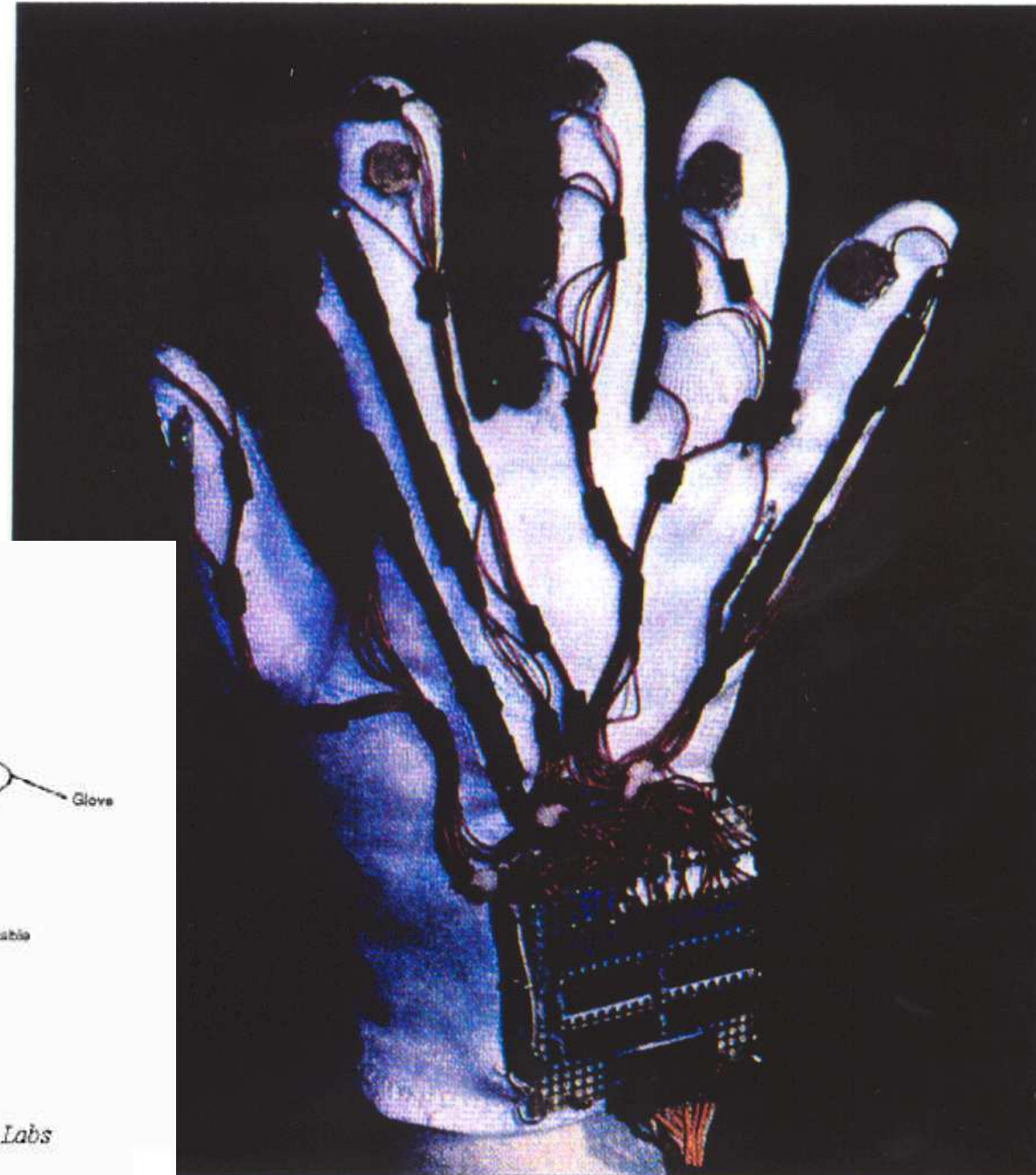
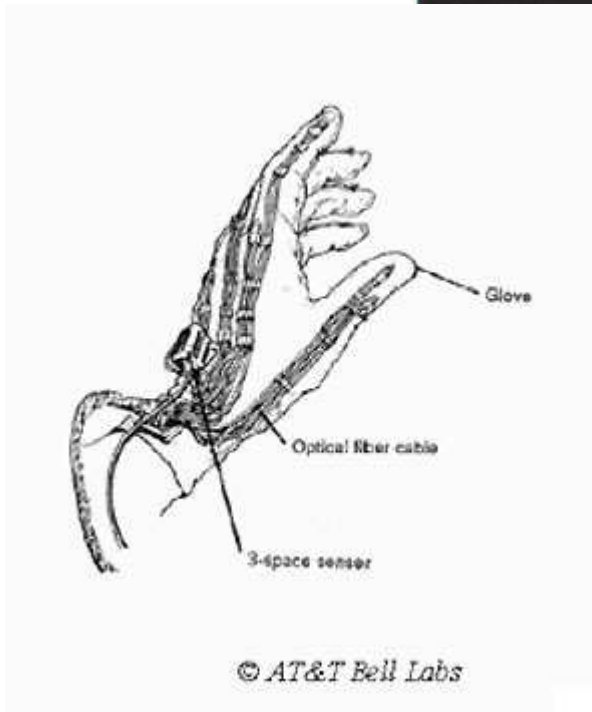



# Data Glove (1987)







# Power Glove (1990)





# Cyber Glove (1995)

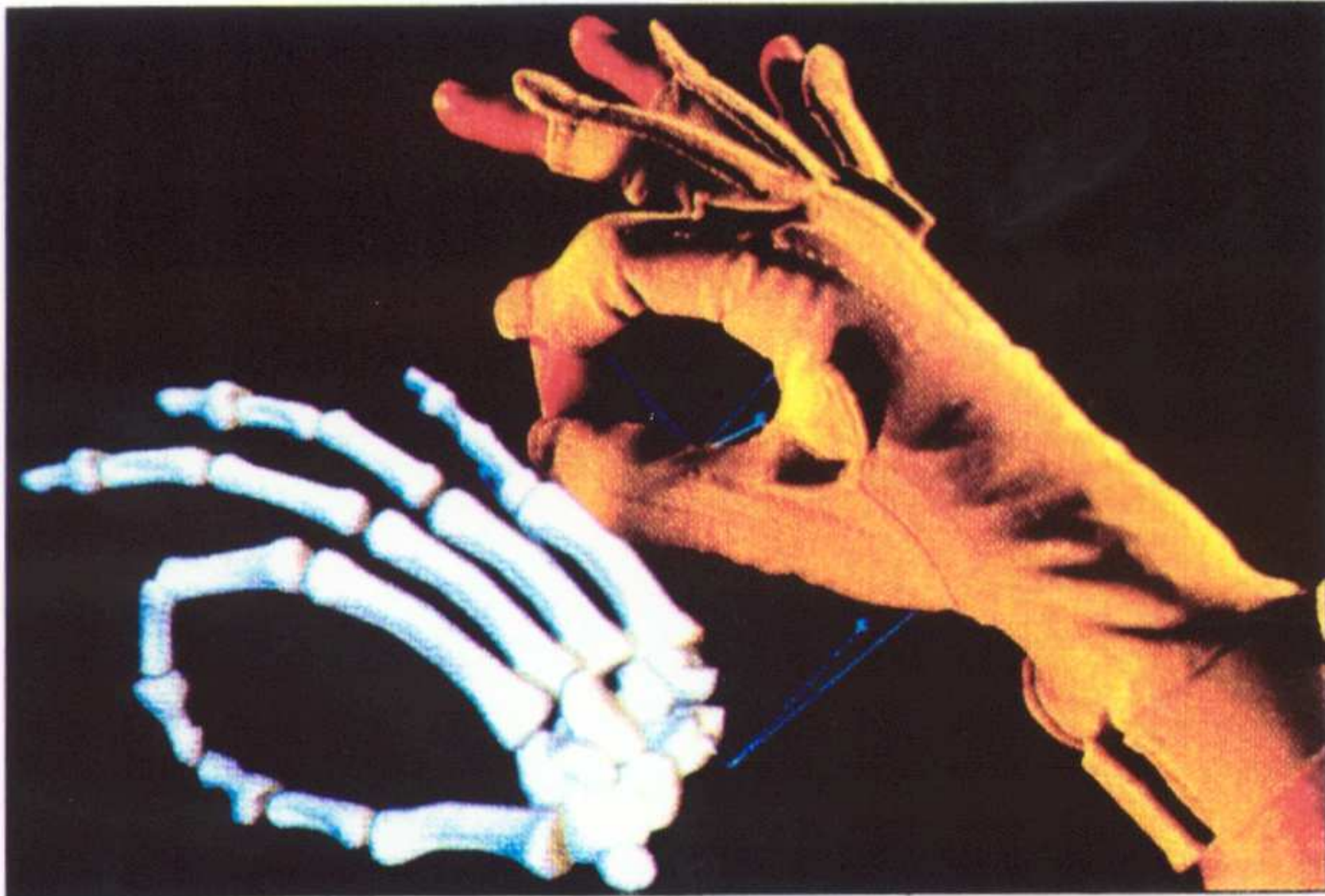



# AcceleGlove / iGlove (2009)



[http://www.anthrotronix.com/index.php?option=com\\_content&view=article&id=87&Itemid=138](http://www.anthrotronix.com/index.php?option=com_content&view=article&id=87&Itemid=138)





# Calibration



Estimate of the geometrical parameters in the transformation operated by the sensors (e.g. the perspective transformation operated by a video-camera).

Estimate of the parameters, which describe distortions introduced by the measurement system.

Measurement of a known pattern. From its distortion, the parameters can be computed.

Algorithms adopted: polynomial, local correction (neural networks, fuzzy).



# Finger tracking through cameras



LEAP  
MOTION

PRODUCT VR APPS DEVELOPER SOLUTIONS COMMUNITY SETUP BUY

### HP Leap Motion Keyboard

The HP Leap Motion Keyboard is the first-ever keyboard with integrated Leap Motion technology. Plug into a compatible HP device and transform the way you experience your digital world.



# Gaze input



- Contact lenses carrying magnetic coils.
- TVcameras aligned with an IR LED source.
- Stereoscopic eye-wear.
- The direction of gaze is decided by measuring the shape of the spot reflected by the frontal portion of the cornea (Ohshima et al., 1996).
- Eye trax <http://www.eyetrax.it/en/index.html>

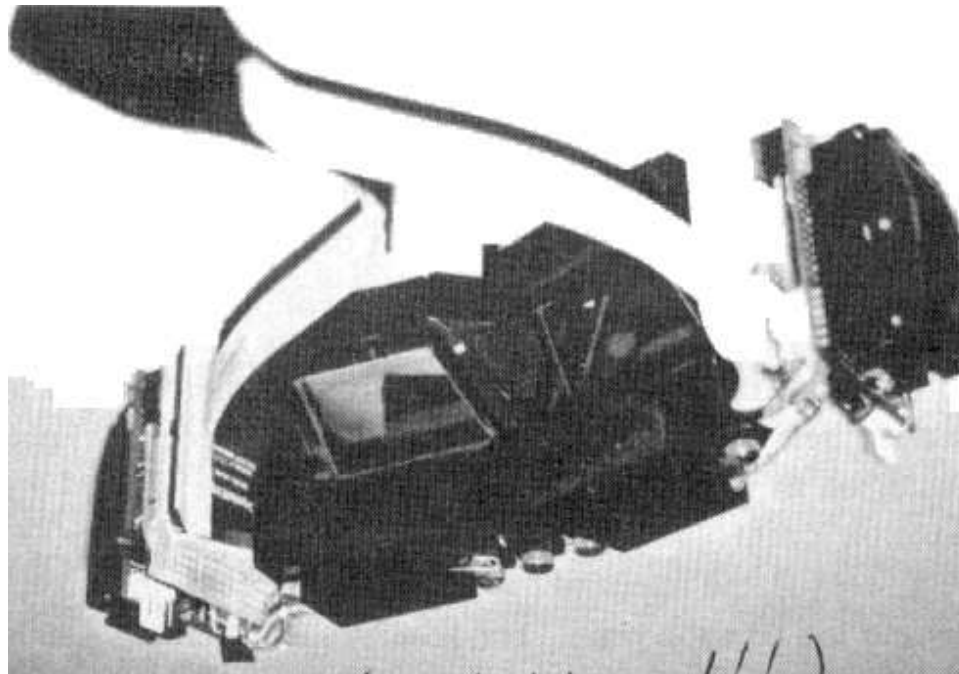



# Vision based eye trackers



Logitech Quickcam 4000

- Color information
- Geometry information (circles, relative position...)
- Histogram analysis on gray level.
- Custom tool for many WEBcams
- ...



EyeTribe - <https://theyetribe.com/>. Passive. 99 US \$



# History



Video technology (semi-automatic marker detection, slow-motion, 1975)

Optoelecontric active markers: Selspot™ 1977 (Selspot II 1993), Watsmart™ 1985, Optotrack™ 1992, Polaris™ 1998. <http://www.ndigital.com/home.html>

Automatic video marker detection:

Vicon™ 1981. <http://www.oxfordmetrics.com/>

Elite™ 1988. <http://www.bts.it/>

MotionAnalysis™ 1992, Eagle™ 2001. <http://www.motionanalysis.com/>

Smart™ 2000. <http://www.motion-engineering.com/>

Magnetic systems:

Sensors: Polhemus 1987, Fastrack 1993. <http://www.polhemus.com/>

Systems: Flock of birds 1994. <http://www.ascension-tech.com/>

Inertial systems: Xmoven Xsense 2000, Wii 2008.

Video processing: organicmotion 2010.

3D video systems: Kinect 2010, <http://www.microsoft.com/en-us/kinectforwindows/>



# Sommario



- Introduzione
- Sistemi di Input
- Generatori di mondi
- Motore di calcolo
- Sistemi di Output
- Conclusioni