



# I circuiti logici: definizione delle funzioni logiche

Prof. Alberto Borghese  
Dipartimento di Informatica  
[borgnese@di.unimi.it](mailto:borgnese@di.unimi.it)

Università degli Studi di Milano

Riferimenti al testo: Appendice B, sezioni B.1 e B.2



## Sommario

Variabili ed operatori semplici.

Implementazione circuitale (porte logiche).

Dal circuito alla funzione.

Algebra Booleana.



Le appendici del Patterson sono on-line...



<http://online.universita.zanichelli.it/patterson-4e/xstudx-appendici/>

A P P E N D I X

## The Basics of Logic Design

*I always loved that word, Boolean.*

**Claude Shannon**  
*IEEE Spectrum, April 1992*  
(Shannon's master's thesis showed that the algebra invented by George Boole in the 1800s could represent the

- B.1 Introduction** B-3
- B.2 Gates, Truth Tables, and Logic Equations** B-4
- B.3 Combinational Logic** B-9
- B.4 Using a Hardware Description Language** B-20
- ■ ■ **Constructed a Basic Arithmetic Logic**



## Le operazioni logiche fondamentali



NOT

AND

OR

**QUALUNQUE** funzione booleana (logica) può essere espressa combinando opportunamente tre funzioni booleane elementari.

Si dice anche che AND, OR, NOT formano un set completo.



# Circuiti Booleani



“An Investigation of the Laws of Thought on Which to Found the Mathematical Theories of Logic and Probabilities” G. Boole, 1854: approccio alla logica come algebra.

Variabili (binarie, 0 = FALSE; 1 = TRUE).  
Operazioni sulle variabili (NOT, AND, OR).

[Equivalenza tra operazioni logiche su proposizioni vere/false e operazioni algebriche su variabili binarie.](#)

### Utilizzo dell'algebra Booleana per:

- Progettazione (sintesi) dei circuiti digitali. Data una certa funzione logica, sviluppare il circuito digitale che la implementa (implementeremo anche le operazioni aritmetiche come funzioni logiche!).
- Analisi dei circuiti. Descrizione della funzione logica implementata dai circuiti.
- Semplificazione di espressioni logiche per ottenere implementazioni efficienti.



# Rappresentazione delle funzioni logiche



	A	B	C	Y
0	F=0	F=0	F=0	F=0
1	F=0	F=0	V=1	V=1
2	F=0	V=1	F=0	F=0
3	F=0	V=1	V=1	F=0
4	V=1	F=0	F=0	F=0
5	V=1	F=0	V=1	V=1
6	V=1	V=1	F=0	V=1
7	V=1	V=1	V=1	V=1

$(A,B,C) \rightarrow Y$

Input (dominio)      Output (codominio)

**Tabella della verità (truth table – TT)**

Vengono considerate tutte le combinazioni possibili in input, terna A,B,C, dove ciascuna variabile può assumere i valori (V,F). Le combinazioni in ingresso si possono indicizzare con i numeri interi: 0 (000), 1 (001), 2 (010), 3 (011), 4 (100), 5 (101), 6 (110), 7 (111).

Per ogni combinazione in input viene prescritto l'output, Y, desiderato (V,F).



## Porte logiche



Gli operatori logici vengono implementati da dei circuiti elettronici che sono chiamati porte logiche

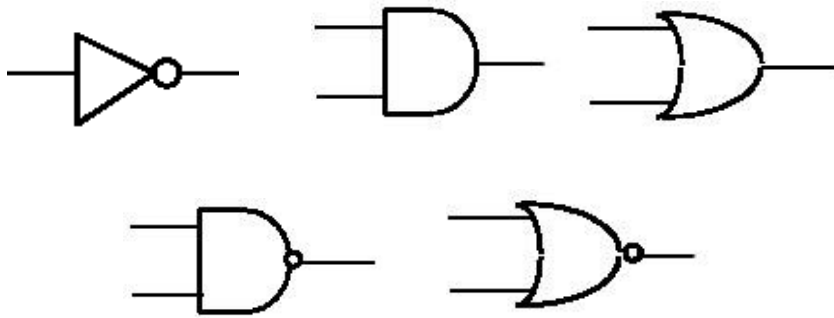

## Operatore NOT



Tabella della verità

A	Y
F = 0	1 = V
V = 1	0 = F

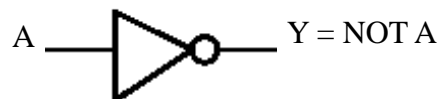

“Inverter logico” : se **A** è vero ( $A = \text{TRUE} = 1$ ),  
**NOT A** è falso ( $\text{FALSE} = 0$ )  
e viceversa.

Scrittura algebrica:  $\text{NOT } A = \overline{A} = !A$



## Operatore AND



A	B	Y
FF	0	0 F
FV	0	1 F
VF	1	0 F
VV	1	1 V

Tabella della verità

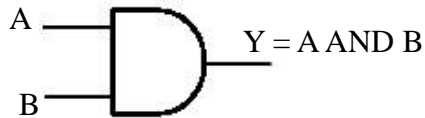

Esempio: “Se c’è il sole e c’è Michela (Michele) vado a sciare”

Scrittura algebrica:  $Y = A \text{ AND } B = A \cdot B = AB$



## Operatore OR



A	B	Y
0	0	0
0	1	1
1	0	1
1	1	1

Tabella della verità



Esempio: “Se c’è il sole o c’è Michela (Michele) vado a sciare”

Scrittura algebrica:  $Y = A \text{ OR } B = A + B$



## Somma e prodotto logico



### Somma logica

=> OR

A	B	Y
0	0	0
0	1	1
1	0	1
1	1	1

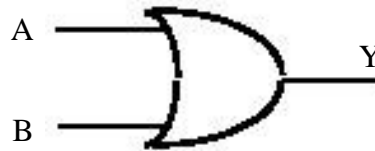

### Prodotto logico

=> AND

A	B	Y
0	0	0
0	1	0
1	0	0
1	1	1

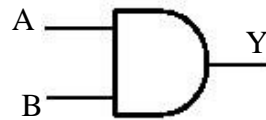

## Concatenazione del NOT

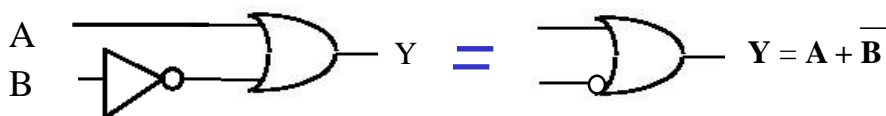

Inserire un cerchietto all'ingresso corrisponde a negare (complementare) quell'ingresso.

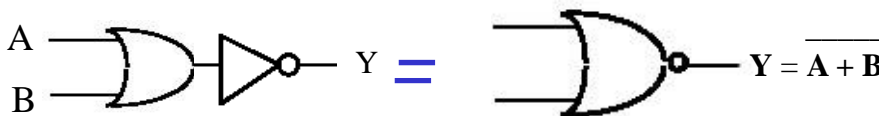

Inserire un cerchietto all'uscita corrisponde a negare (complementare) l'uscita.



## Tabella della verità



A	B	Y
0	0	1
0	1	0
1	0	1
1	1	1

$$Y = \text{OR}(A, \overline{B})$$

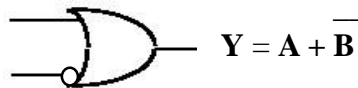

Questa funzione è diversa dalla funzione  $\text{OR}(A,B)$   
La tabella della verità è diversa.



## Operatore NOR



A	B	$\text{OR}(A,B)$	Y
0	0	0	1
0	1	1	0
1	0	1	0
1	1	1	0

Operatore OR negato

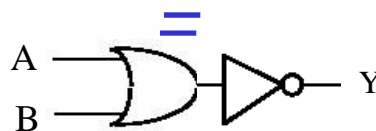
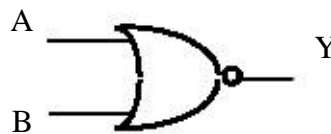

“ $\text{Not}(\text{Or}(A,B))$ ”

$$Y = \overline{A + B} = \overline{!(A + B)}$$



## Operatore NAND



A	B	AND(A,B)	Y
0	0	0	1
0	1	0	1
1	0	0	1
1	1	1	0

*"Not(And(A,B))"*

$$Y = \overline{A B}$$

Operatore AND negato

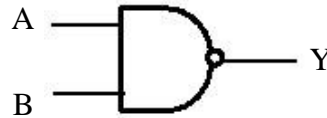

=

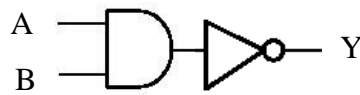

## Porte logiche a più ingressi



- Rappresentano circuiti che forniscono in uscita il risultato di operazioni logiche elementari sui valori di tutte le variabili in ingresso
- Le variabili in ingresso possono essere n.

Ad esempio:

$$Y = A \text{ AND } B \text{ AND } C \text{ AND } D$$

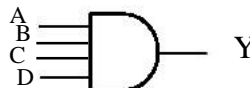





## Porte logiche: tabella della verità



A	B	C	D	Y
0	0	0	0	0
0	0	0	1	0
0	0	1	0	0
0	0	1	1	0
0	1	0	0	0
0	1	0	1	0
0	1	1	0	0
0	1	1	1	0
1	0	0	0	0
1	0	0	1	0
1	0	1	0	0
1	0	1	1	0
1	1	0	0	0
1	1	0	1	0
1	1	1	0	0
1	1	1	1	1

$$Y = A \text{ AND } B \text{ AND } C \text{ AND } D$$

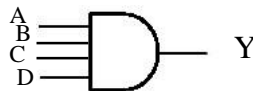

## Sommario



Variabili ed operatori semplici.

Implementazione circuitale (porte logiche).

Dal circuito alla funzione.

Algebra Booleana.



## Il Transistor



- Modello: interruttore tra **Emettitore** e **Collettore**, **comandato** dalla tensione sulla **Base**.
- Le porte logiche sono costituite da transistor.
- 2 casi “estremi”:
  - Tensione  $V_{BE}$  **bassa** → **C,E isolati (spento)**
    - Transistor in stato di **INTERDIZIONE**
  - Tensione  $V_{BE}$  **alta** → **C,E collegati (acceso)**
    - Transistor in stato di **SATURAZIONE** ( $V_C = V_E$ )

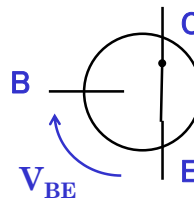
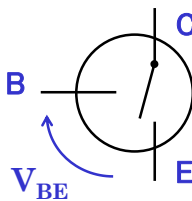
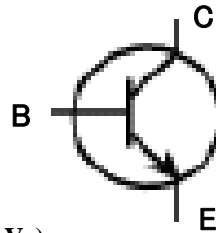

## La tecnologia CMOS: dal 1980 a oggi



- **CMOS**: Complementary–MOS (Frank Wanlass, 1967 Fairchild)
  - MOS: **M**etal – **O**xide **S**emiconductor
  - MOS complementari (**N**-MOS + **P**-MOS) che lavorano “in coppia”: substrati comuni.

nMOS è acceso se:  $V_{GS} > \text{soglia}$   
 $V_G \approx V_{dd}$

pMOS è acceso se:  $V_{DG} > \text{soglia}$   
 $V_G \approx V_{ss}$

Un MOS:

- Quando è acceso funziona da corto circuito tra DS
- Quando è spento funziona da circuito aperto tra DS

Acceso se:  $V_{in} > V_{dd}/2$

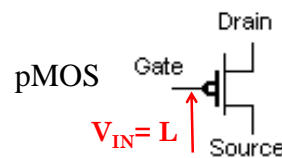
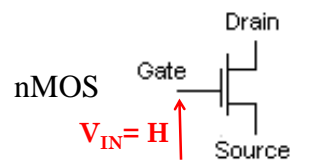

Acceso se:  $V_{in} < V_{dd}/2$



## La tecnologia CMOS: vantaggi



- Vantaggi:

- Tensione di alimentazione,  $V_{CC}$ , “flessibile”:

$$V_{CC} = 1 \div 15 \text{ Volt (vicina a 1 V quasi sempre)}$$

$$V_{LOW} = 0 \approx V_{ss} \text{ (tensione di source)}$$

$$V_{HIGH} = 1 \approx V_{dd} \text{ (tensione di drain)}$$

- Consumo bassissimo:

- Consuma solo nella transizione
- In condizioni statiche, consumo praticamente nullo!

Si può vedere come un ponte levatoio che si alza e si abbassa tra Drain e Source ed è pilotato dal gate. Si consuma energia solo quando viene alzato o abbassato.

Acceso se:  $V_{in} > V_{dd}/2$

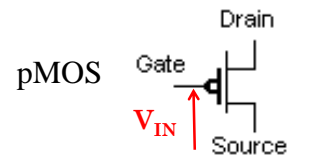
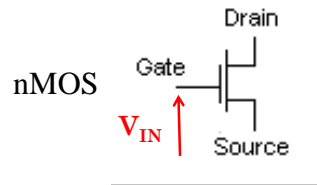

Acceso se:  $V_{in} < V_{dd}/2$



## La porta NOT in CMOS



2 MOS complementari

$V_{in} = L = 0V$  il transistor inferiore è spento,  $V_{out} = V_{dd} = H$

$V_{in} = H = V_{dd}$  passa corrente nel transistor inferiore, la resistenza è molto bassa e  $V_{out} \cong 0 = L$ . Il transistor superiore è spento.

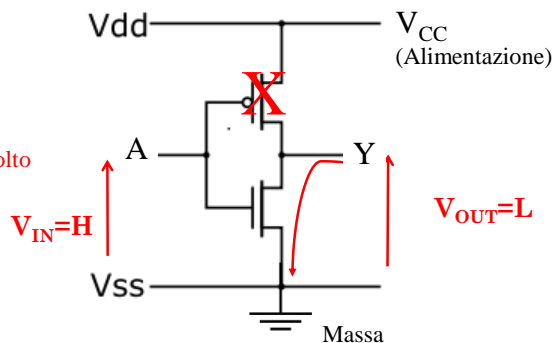

La porta NOT è chiamata anche Inverter logico.



## Porta NAND e AND in C-MOS



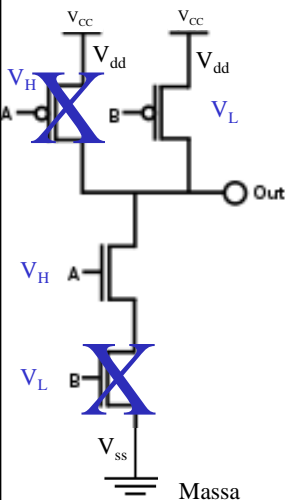

Massa

$V_A$	$V_B$	$V_{OUT}$
$V_H=1$	$V_H=1$	$V_L=0$
$V_H=1$	$V_L=0$	$V_H=1$
$V_L=0$	$V_H=1$	$V_H=1$
$V_L=0$	$V_L=0$	$V_H=1$

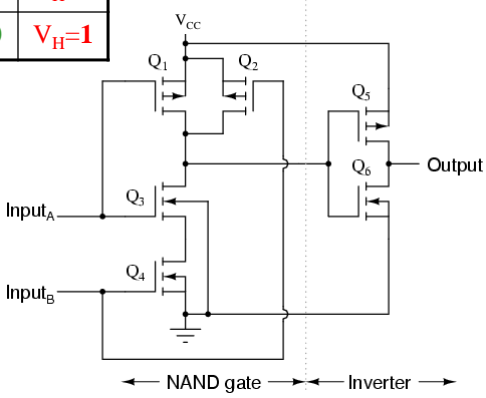

← CMOS AND gate

← NAND gate → Inverter →

A.A. 2021-2022
23/49
<http://borghese.di.unimi.it/>



## Porta NAND in C-MOS all'opera



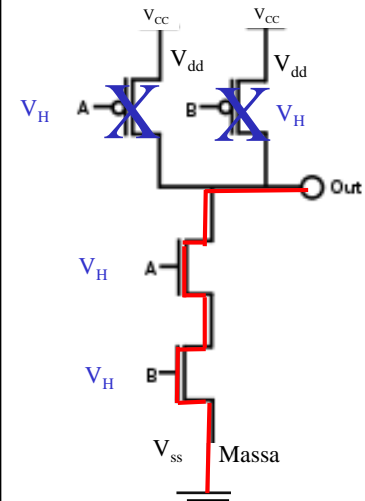

Massa

$V_A = 1; V_B = 1 \rightarrow V_{out} = V_{ss} = 0$

$V_1$	$V_2$	$V_{OUT}$
$V_H=1$	$V_H=1$	$V_L=0$
$V_H=1$	$V_L=0$	$V_H=1$
$V_L=0$	$V_H=1$	$V_H=1$
$V_L=0$	$V_L=0$	$V_H=1$

A.A. 2021-2022
24/49
<http://borghese.di.unimi.it/>



# PORTA NOR e OR IN CMOS



$V_1$	$V_2$	$V_{OUT}$
$V_H=1$	$V_H=1$	$V_L=0$
$V_H=1$	$V_L=0$	$V_L=0$
$V_L=0$	$V_H=1$	$V_L=0$
$V_L=0$	$V_L=0$	$V_H=1$

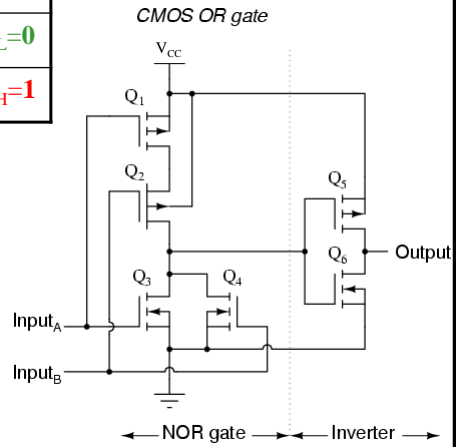
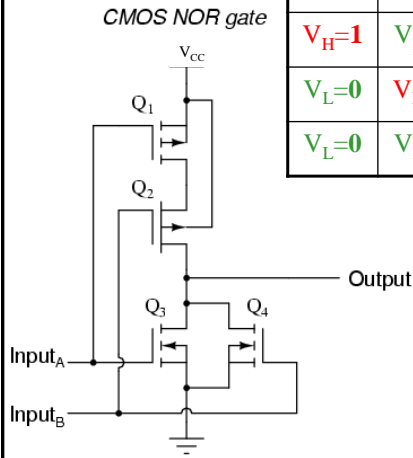

# Perchè l'elettronica digitale funziona?



Perchè è progettata per essere resistente al rumore.

Vengono definiti 2 range di tensioni associati ai valori alto e basso, separati da un gap.

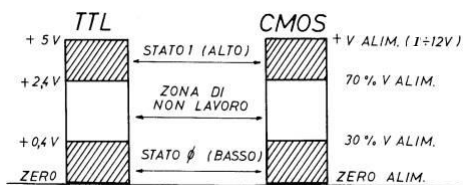



# Tempo di commutazione

La commutazione non è istantanea

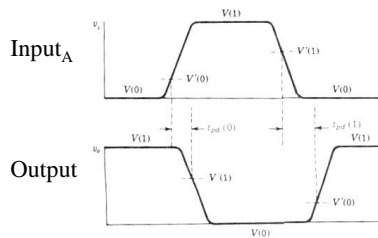
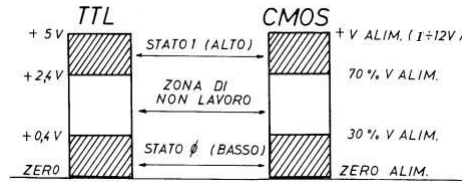
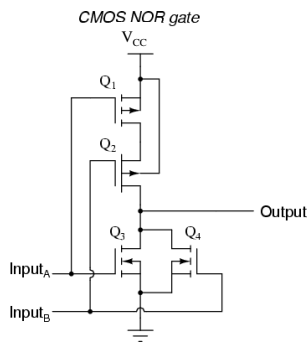

Più porte in cascata generano un ritardo nella commutazione dell'uscita.

Numero limitato di porte logiche che si possono collegare in ingresso e in uscita (fan-in / fan-out)



# Sommario

Variabili ed operatori semplici.

Implementazione circuitale (porte logiche).

Dal circuito alla funzione.

Algebra Booleana.



## Funzione



- Una relazione che associa ad ogni elemento dell'insieme  $X: \{x\}$ , detto dominio, associa un elemento dell'insieme  $Y: \{y\}$ , detto codominio, indicandola con  $y = f(x)$  (Wikipedia).  
Sinonimi: mappa, trasformazione.
- Le nostre funzioni saranno tipicamente relazioni tra ingressi e uscite multi-dimensionali (più variabili in ingresso e più variabili in uscita).
- Nulla è detto sulla forma di questa relazione.
  - Funzione analitica (e.g.  $Y = \sin(x) \log(\cos(x/2))$ )...
  - Funzione a più valori di input e più valori di output (x ed y vettori)
  - Tabella di corrispondenza (tabella di verità).
  - ....



## Funzioni logiche



- Funzione a  $n$  ingressi e  $m$  uscite. Per ciascuna delle  $2^n$  combinazioni degli ingressi, può essere calcolata ciascuna delle uscite.
- E' una funzione discreta con domini finiti. **Si può calcolare per tutti i punti nei quali la funzione è definita.**
- La funzione logica sarà implementata da un'opportuna combinazione di porte semplici (NOT, AND, OR) che prendono gli  $n$  ingressi e li trasformano nell'uscita specificata.
- La funzione logica sarà calcolata da un circuito con  $n$  ingressi, costituito da porte logiche.
- Il valore della funzione può essere rappresentato in 3 modi:
  - Circuito
  - Tabella della verità (Truth Table, TT).
  - Espressione simbolica



## Dal circuito alla TT



$$F = (A \text{ AND } B) \text{ OR } (B \text{ AND NOT}(C))$$

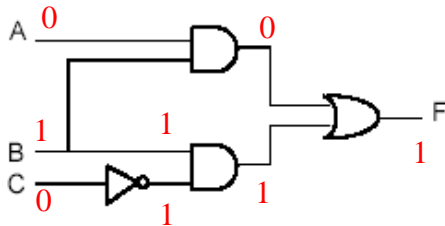

A	B	C	F
0	0	0	0
0	0	1	0
0	1	0	1
0	1	1	0
1	0	0	0
1	0	1	0
1	1	0	1
1	1	1	1

Direzione del calcolo



## Dal circuito alla TT - 2



$$F = (A \text{ AND } B) \text{ OR } (B \text{ AND NOT}(C))$$

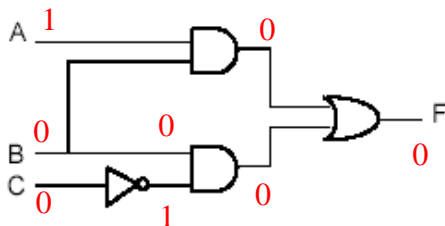

A	B	C	F
0	0	0	0
0	0	1	0
0	1	0	1
0	1	1	0
1	0	0	0
1	0	1	0
1	1	0	1
1	1	1	1

Direzione del calcolo





## Dall'espressione logica alla TT



- Data l'espressione:  $F = (A \text{ AND } B) \text{ OR } (B \text{ AND NOT}(C))$

Ricaviamo la tabella delle verità:

A B C	A and B	B and not(C)	F
0 0 0	0	0	0
0 0 1	0	0	0
0 1 0	0	1	1
0 1 1	0	0	0
1 0 0	0	0	0
1 0 1	0	0	0
1 1 0	1	1	1
1 1 1	1	0	1



## Circuiti equivalenti

a b c	y
0 0 0	0
0 0 1	0
0 1 0	1
0 1 1	0
1 0 0	0
1 0 1	0
1 1 0	1
1 1 1	1

Espressioni algebriche e tabella danno la stessa uscita y

Espressioni algebriche (e circuiti diversi) possono implementare la stessa funzione logica (stessa TT)

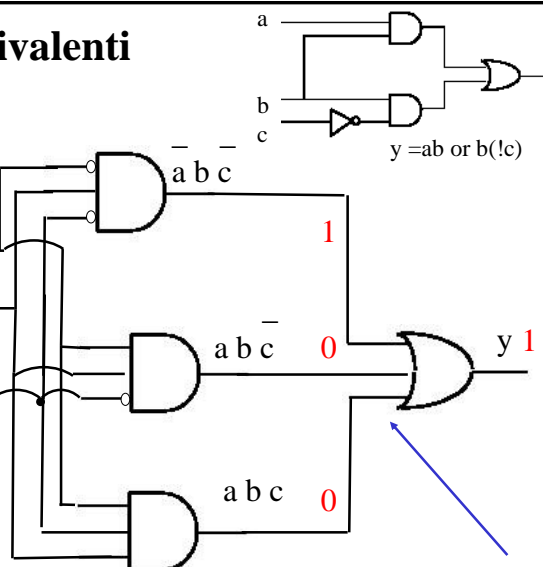

Implementazione circuitale possibile. Non è l'unica!

$$y = abc + abc + abc$$



## Circuiti equivalenti - 2

a	b	c	y
0	0	0	0
0	0	1	0
0	1	0	1
0	1	1	0
1	0	0	0
1	0	1	0
1	1	0	1
1	1	1	1

**Funzione e tabella danno la stessa uscita y.**

**Espressioni algebriche diverse e circuiti diversi possono implementare la stessa funzione logica (stessa TT).**

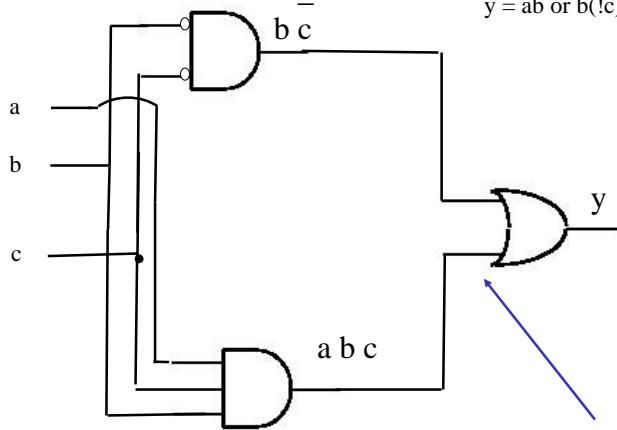
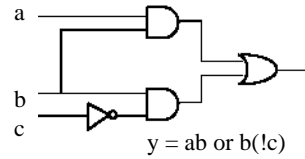

Implementazione circuitale possibile.  
Non è l'unica!

35/49

<http://borgnese.di.unimi.it/>



## Sommario



Variabili ed operatori semplici.

Implementazione circuitale (porte logiche).

Dal circuito alla funzione.

**Algebra Booleana.**



## Concatenazione degli operatori - I



In assenza di parentesi, AND ha la priorità sull'OR ed il NOT su entrambi:

$$A + B \cdot C = A + (B \cdot C)$$

per eseguire prima OR occorre scrivere esplicitamente:  $(A+B) \cdot C$

In assenza di parentesi, la negazione ha la priorità sugli altri operatori.

$$\text{NOT } A \cdot C = (\text{NOT}(A)) \cdot C = \bar{A}C$$

—  
A B C Eseguo prima la negazione. Quindi eseguo prima l'AND di A e B, nego il risultato dell'AND ed infine eseguo l'AND con C:

- 1) AB
- 2) !(AB)
- 3) (!(AB) C)

A.A.



## Concatenazione degli operatori - II



$$\bar{\bar{A}} \bar{\bar{B}} = (\bar{A}) (\bar{B})$$

- 1) Prima eseguo la negazione di A e la negazione di B in parallelo.
- 2) Poi eseguo l'AND.

$$\bar{\bar{A}} \bar{\bar{B}} C = [(\bar{A}) (\bar{B})] C$$

- 1) Prima eseguo la negazione di A e la negazione di B in parallelo.
- 2) Eseguo il prodotto logico di !A, !B e C.

Anche sulle negazioni esiste una gerarchia:

$$\overline{(\bar{A} \bar{B})} = \overline{(\bar{A}) (\bar{B})} = ! ( (!A) (!B) )$$

- 1) Prima eseguo la negazione di A e la negazione di B in parallelo.
- 2) Eseguo poi l'AND di !A e !B = AND(!A, !B)
- 3) Nego il risultato dell'AND

A.A.



## Manipolazione algebrica - I



	AND	OR
<b>Identità</b>	$1 x = x$	$0 + x = x$
<i>Algebra classica</i>	$1 N = N$	$0 + N = N$

<b>Elemento nullo</b>	$0 x = 0$	$1 + x = 1$
<i>Algebra classica</i>	$0 N = 0$	-----

*Uno degli ingressi della porta AND funge da interruttore:  
 = 0, uscita è sempre =0, interruttore aperto  
 = 1, uscita è uguale all'ingresso, interruttore chiuso.*

<b>Inverso</b>	$\bar{x} x = 0$	$\bar{x} + x = 1$
<i>Algebra classica</i>	-----	-----

<b>Idempotenza</b>	$x x = x$	$x + x = x$
<i>Algebra classica</i>	-----	-----



## Manipolazione algebrica - II



<b>Doppia Inversione</b>	$\bar{\bar{x}} = x$	-----
<i>Algebra classica</i>	-----	-----

<b>Associativa</b>	$(x y) z = x (y z)$	$(x + y) + z = x + (y + z)$
<i>Algebra classica</i>	$(NM)K = N(MK)$	$(N+M)+K = N+(M+K)$

<b>Commutativa</b>	$x y = y x$	$x + y = y + x$
<i>Algebra classica</i>	$NM = MN$	$N + M = M + N$

*AND rispetto ad OR OR rispetto ad AND*

<b>Distributiva</b>	$x (y + z) = x y + x z$	$x + y z = (x + y ) (x + z)$
<i>Algebra classica</i>	$N(M+K) = NM+NK$	-----

<b>Assorbimento</b>	$x (x + y) = x$	$x + x y = x$
<i>Algebra classica</i>	-----	-----



## Principio di dualità



Nell'algebra di Boole vale il principio di dualità.

Il duale di una funzione booleana si ottiene sostituendo AND ad OR, OR ad AND, gli 0 agli 1 e gli 1 agli 0.

Esempi:

- Identità  $1 x = x$   $0 + x = x$
- Elemento nullo  $0 x = 0$   $1 + x = 1$

**Proprietà Commutativa:**

$$x y = y x$$

$$x + y = y + x$$

• **Proprietà distributiva:**

$$x (y + z) = xy + xz$$

$$x + (y z) = x + yz$$

• **Assorbimento:**

$$x (x + y) = x$$

$$x + x y = x$$



## Teoremi di De Morgan



Enunciati:

$$I) \overline{xy} = \overline{x} + \overline{y}$$

$$II) \overline{x + y} = \overline{x} \overline{y}$$

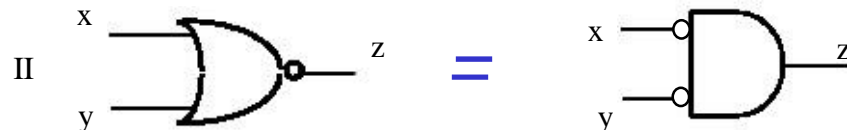
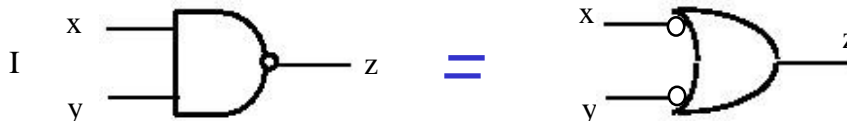



## Regole algebriche



Doppia Inversione	$\overline{\overline{x}} = x$	
<b>Identità</b>	<b>AND</b> $1 x = x$	<b>OR</b> $0 + x = x$
<b>Elemento nullo</b>	$0 x = 0$	$1 + x = 1$
<b>Idempotenza</b>	$x x = x$	$x + x = x$
<b>Inverso</b>	$x \overline{x} = 0$	$x + \overline{x} = 1$
<b>Commutativa</b>	$x y = y x$	$x + y = y + x$
<b>Associativa</b>	$(x y) z = x (y z)$	$(x + y) + z = x + (y + z)$
<b>Distributiva</b>	<b>AND rispetto ad OR</b> $x (y + z) = x y + x z$	<b>OR rispetto ad AND</b> $x + y z = (x + y) (x + z)$
<b>Assorbimento</b>	$x (x + y) = x$	$x + x y = x$
<b>De Morgan</b>	$\overline{xy} = \overline{x} + \overline{y}$	$\overline{x + y} = \overline{x} \overline{y}$



## Porta Universale NOR



- NOT A = 0 NOR A
- A OR B = (A NOR B) NOR 0
- A AND B = (A NOR 0) NOR (B NOR 0)

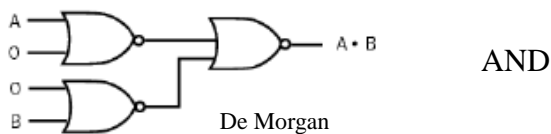
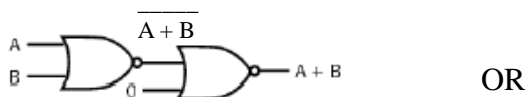



## De Morgan NOR -> AND



De Morgan:  $A+B = \overline{\overline{A} \overline{B}}$

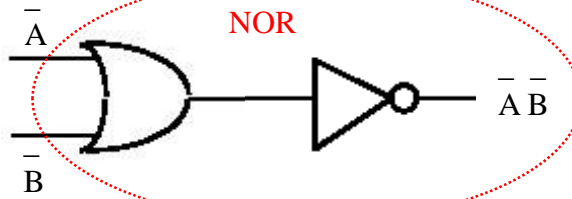

Questo circuito con NOR è equivalente a  $AND(\overline{A}, \overline{B})$ . Come faccio con le negazioni?

Applico la negazione agli ingressi:

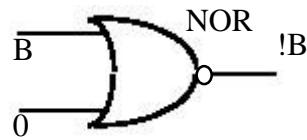
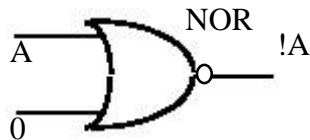

## De Morgan NOR -> AND

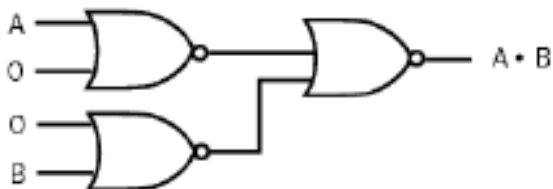
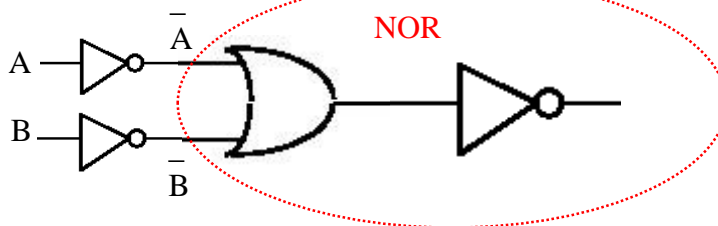



## De Morgan in generale



Quale funzione è implementata da questo circuito?

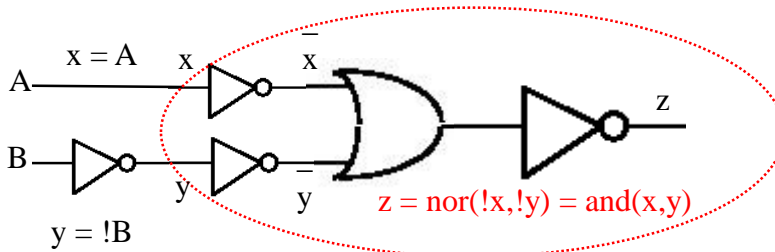

$$z = \text{AND}(x,y)$$

Sostituisco il not e ottengo:  $z = \text{and}(A,!B) = A \overline{B}$



## Esercizio



Data la funzione booleana:

$$F = (A \text{ AND } B) \text{ OR } (B \text{ AND NOT}(C))$$

Esprimere la funzione F con il solo connettivo logico NOR e disegnare il circuito.

Esprimere la funzione F con il solo connettivo logico NAND e disegnare il circuito.

Costruire le porte logiche: AND, OR, NOT utilizzando solo la porta NAND.





# Sommario



Variabili ed operatori semplici.

Implementazione circuitale (porte logiche).

Dal circuito alla funzione.

Algebra Booleana.