



# I circuiti binari: definizione delle funzioni logiche

Prof. Alberto Borghese  
Dipartimento di Scienze dell'Informazione  
[borgnese@dsi.unimi.it](mailto:borgnese@dsi.unimi.it)

Università degli Studi di Milano

Riferimenti al testo: Appendice B, sezioni B.1 e B.2



## Sommario

Variabili ed operatori semplici.

Implementazione circuitale (porte logiche).

Dal circuito alla funzione.

Algebra Booleana.



## Le operazioni logiche fondamentali



NOT

AND

OR



## Circuiti Booleani



“An Investigation of the Laws of Thought on Which to Found the Mathematical Theories of Logic and Probabilities” G. Boole, 1854: approccio alla logica come algebra.

Variabili (binarie, 0 = FALSE; 1 = TRUE).

Operazioni sulle variabili (NOT, AND, OR).

### Utilizzo dell'algebra Booleana per:

Analisi dei circuiti. Descrizione della funzione logica implementata dai circuiti.

Semplificazione di espressioni logiche per ottenere implementazioni efficienti.

Progettazione (sintesi) dei circuiti digitali. Data una certa funzione logica, sviluppare il circuito digitale che la implementa.



## Operatore NOT



Tabella della verità

A	Y
0	1
1	0

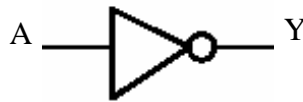

“Inverter logico” : se **A** è vero (**TRUE=1**),  
**NOT A** è falso (**FALSE=0**)

$$\text{NOT } A = \bar{A}$$



## Operatore AND



Tabella della verità

A	B	Y
0	0	0
0	1	0
1	0	0
1	1	1

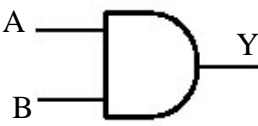

“Prodotto logico”

$$Y = A \text{ AND } B = A \cdot B = AB$$



## Operatore OR



A	B	Y
0	0	0
0	1	1
1	0	1
1	1	1

Tabella della verità



“Somma logica”

$$Y = A \text{ OR } B = A + B$$



## Concatenazione del NOT

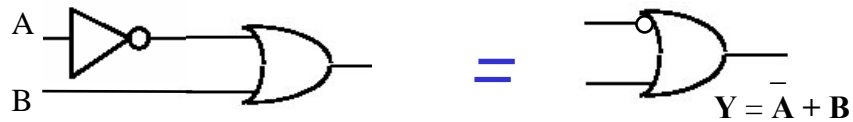
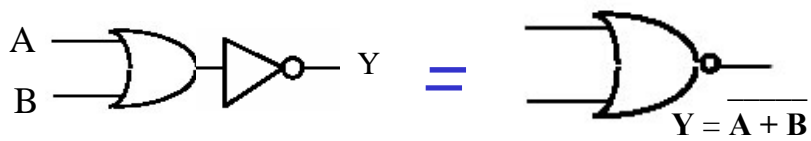

Inserire un cerchietto all'ingresso corrisponde a negare la variabile in ingresso.  
Inserire un cerchietto all'uscita corrisponde a negare (complementare) l'uscita.



## Operatore NOR



A	B	OR(A,B)	Y
0	0	0	1
0	1	1	0
1	0	1	0
1	1	1	0

Operatore OR negato

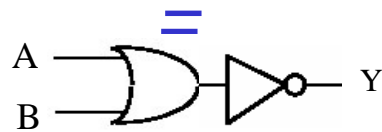
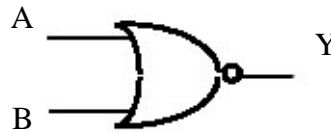

*“Not(Or(A,B))”*

$$Y = \overline{A + B}$$



## Operatore NAND



A	B	AND(A,B)	Y
0	0	0	1
0	1	0	1
1	0	0	1
1	1	1	0

Operatore AND negato

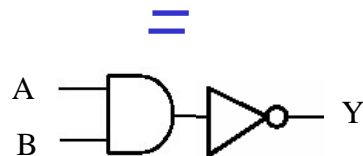
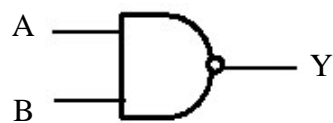

*“Not(And(A,B))”*



## Porte logiche a più ingressi



- Rappresentano circuiti che forniscono in uscita il risultato di operazioni logiche elementari sui valori di tutte le variabili in ingresso
- Le variabili in ingresso possono essere n.

Ad esempio:

$$Y = A \text{ AND } B \text{ AND } C \text{ AND } D$$

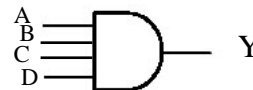

## Porte logiche: tabella della verità



A	B	C	D	Y
0	0	0	0	0
0	0	0	1	0
0	0	1	0	0
0	0	1	1	0
0	1	0	0	0
0	1	0	1	0
0	1	1	0	0
0	1	1	1	0
1	0	0	0	0
1	0	0	1	0
1	0	1	0	0
1	0	1	1	0
1	1	0	0	0
1	1	0	1	0
1	1	1	0	0
1	1	1	1	1

$$Y = A \text{ AND } B \text{ AND } C \text{ AND } D$$

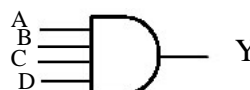



## Sommario



Variabili ed operatori semplici.

Implementazione circuitale (porte logiche).

Dal circuito alla funzione.

Algebra Booleana.



## Il Transistor



- Modello: interruttore tra **Emettitore** e **Collettore**, comandato dalla tensione sulla **Base**.
- 2 casi “estremi”:
  - Tensione  $V_{BE}$  **bassa**  $\rightarrow$  **C,E isolati**
    - Transistor in stato di **INTERDIZIONE**
  - Tensione  $V_{BE}$  **alta**  $\rightarrow$  **C,E collegati**
    - Transistor in stato di **SATURAZIONE** ( $V_C = V_E$ )

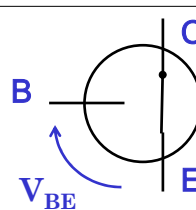
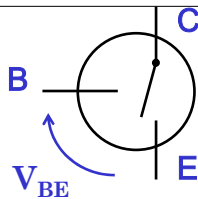
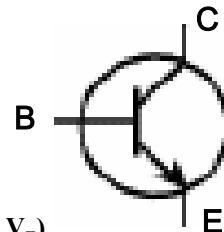



## Inverter logico: porta NOT

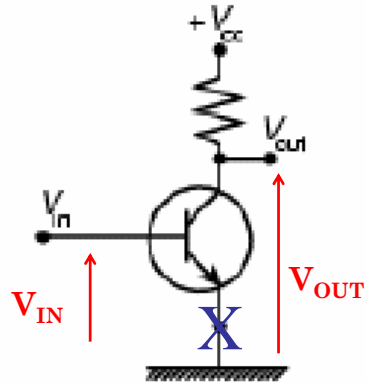

$V_{in} = 0V$  è spento,  $V_{out} = V_{CC}$

$V_{in} = V_{CC}$  passa corrente, la resistenza è molto bassa e  $V_{out} \cong 0$

Si definisce porta logica (**gate**), un dispositivo elettronico in grado di trasformare la tensione agli ingressi secondo gli operatori fondamentali.



## Porta NAND



- **Solo se**  $V_1=V_2=V_H$  → I due transistor sono chiusi e passa corrente,  $V_{OUT} = V_L$
- **Altrimenti** →  $V_{OUT} = V_H$

Tabella della verità

$V_1$	$V_2$	$V_{OUT}$
$V_H=1$	$V_H=1$	$V_L=0$
$V_H=1$	$V_L=0$	$V_H=1$
$V_L=0$	$V_H=1$	$V_H=1$
$V_L=0$	$V_L=0$	$V_H=1$

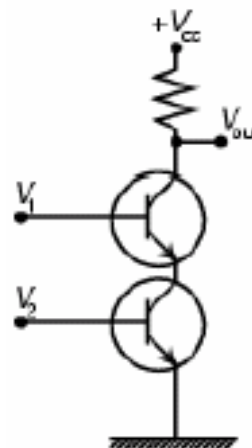





## Porta NOR

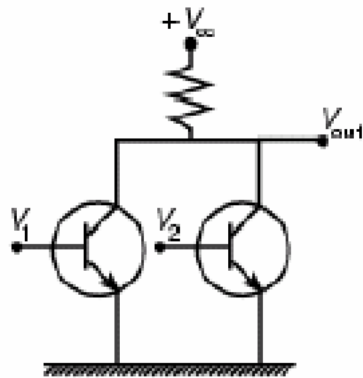

Se  $V_i$  è alto, il transistor corrispondente, conduce e la tensione  $V_{out}$  si avvicina alla massa ( $V_{out} = \text{Low}$ ).

Se  $V_1 = V_2 = 0$  nessun transistor conduce, e  $V_{out}$  viene "tirata" (pull-up) verso la tensione dell'alimentazione.

(c)  
NOR



## NAND in logica RTL



A and B and C = H  $\Rightarrow$  Y = H  
A or B or C = L  $\Rightarrow$  Y = L

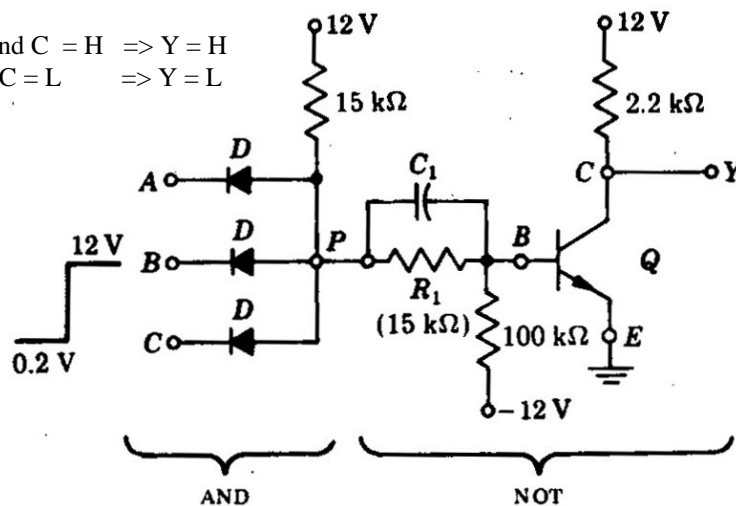

Porta NAND a 3 ingressi in Resistor Transistor Logic (RTL).



## NAND in logica TTL



ABC = High  $\Rightarrow$   $Q_1$  interruttore aperto  
 $Q_2$  chiuso  $\Rightarrow$   $P'' > 0V \Rightarrow Q_3 =$  chiuso  
 $\Rightarrow Y =$  Low

$V_{CC}$  (5 V)

A|B|C = Low  $\Rightarrow$   $Q_1$  interruttore chiuso  
 $Q_2$  aperto  $\Rightarrow$   $P'' = 0V \Rightarrow Q_3 =$  aperto  
 $\Rightarrow Y =$  High.

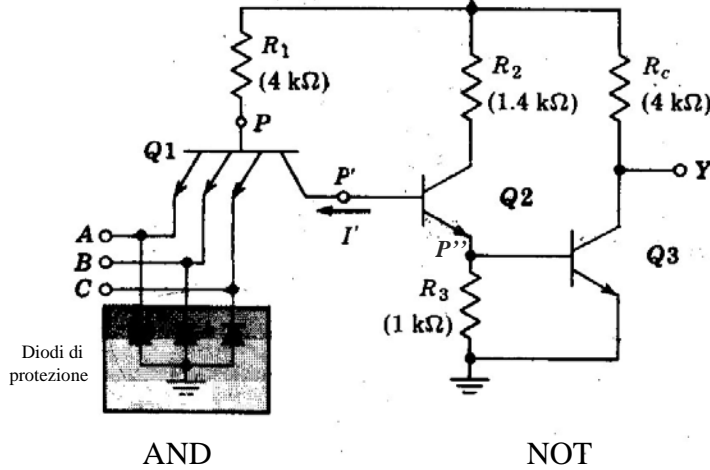

A.A. 2006-2007

19/38

<http://homes.dsi.unimi.it/~borgnese>



## Logica TTL three-state



Stadio di output della porta NAND  
 (configurazione TotemPole)  
 con il segnale di abilitazione.

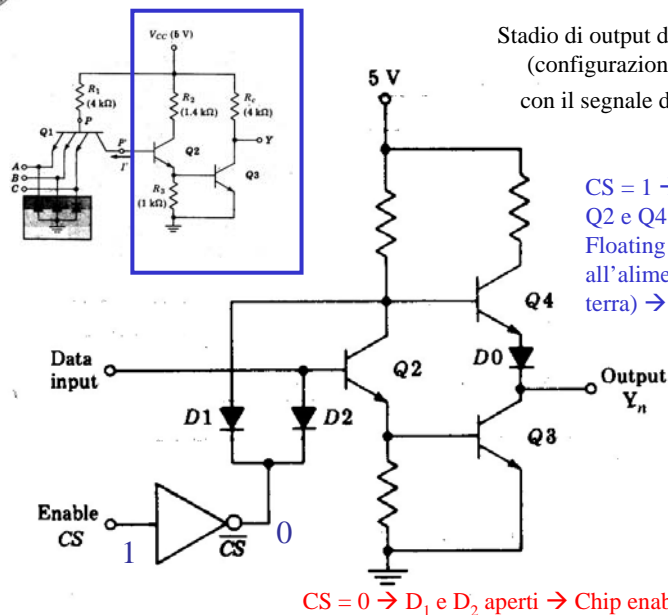

$CS = 1 \rightarrow D_1$  e  $D_2$  chiusi  $\rightarrow$   
 $Q_2$  e  $Q_4$  spenti  $\rightarrow$  Output  
 Floating (nè collegato  
 all'alimentazione, nè alla  
 terra)  $\rightarrow$  Chip disabled

$CS = 0 \rightarrow D_1$  e  $D_2$  aperti  $\rightarrow$  Chip enabled

A.A. 2006-2007

20/38

<http://homes.dsi.unimi.it/~borgnese>

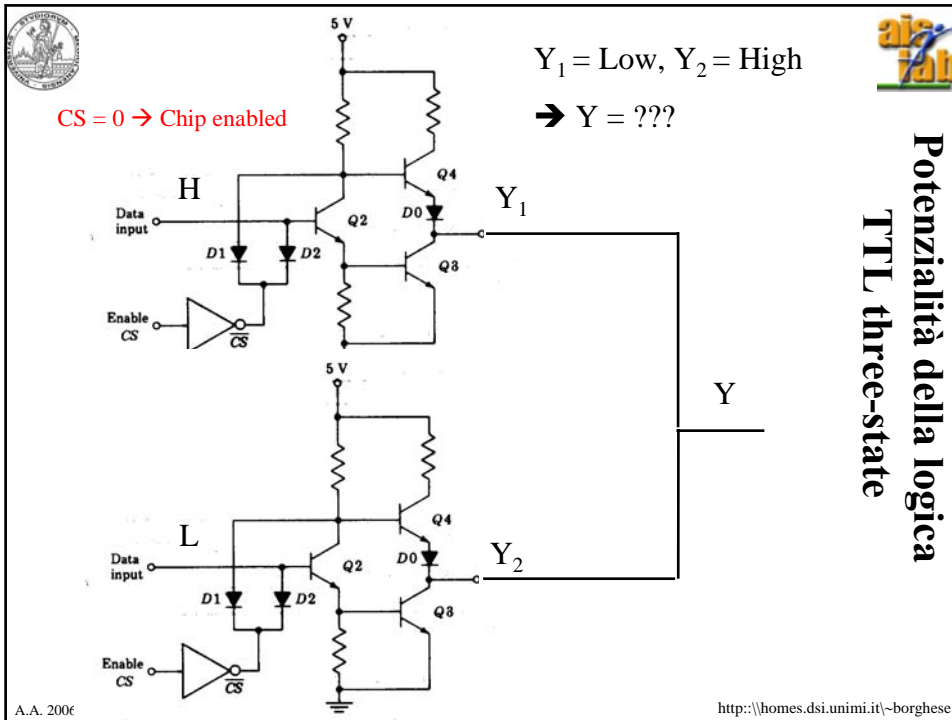

### Tecnologia a 3 stati

0 = Tensione low

1 = Tensione high

Enable = Porta logica non funzionante. Uscita indifferente.  
 Particolarmente utile per le memorie.

A.A. 2006-2007 22/38 http://homes.dsi.unimi.it/~borgnese



# Perchè l'elettronica digitale funziona?



Perchè è progettata per essere resistente al rumore.

Vengono definiti 2 range di tensioni associati ai valori alto e basso, separati da un gap. Per la logica TTL:

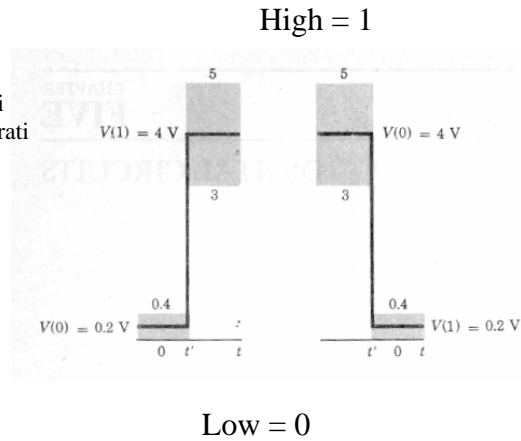

# Tempo di commutazione



La commutazione non è istantanea:

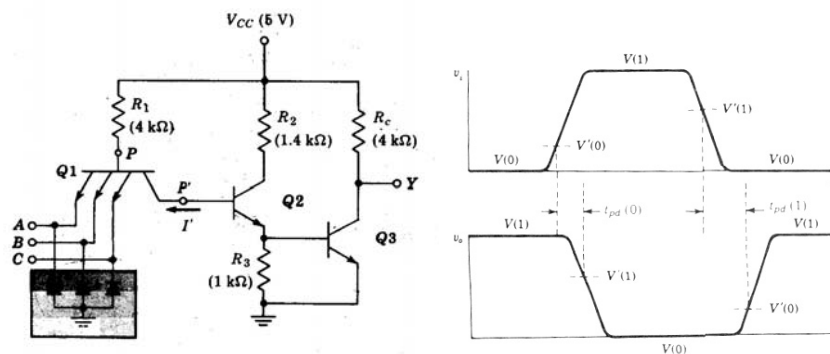

Definizione del cammino critico nei circuiti combinatori.



## Sommario



Variabili ed operatori semplici.

Implementazione circuitale (porte logiche).

**Dal circuito alla funzione.**

Algebra Booleana.



## Funzioni logiche



- La funzione calcolata da un circuito con  $n$  ingressi.
- Il circuito sarà costituito da un'opportuna combinazione di porte semplici (NOT, AND, OR).
- Per ciascuna delle  $2^n$  combinazioni degli ingressi, può essere calcolata l'uscita.
- Il valore della funzione può essere rappresentato in 3 modi:
  - Circuito
  - Tabellato: tabelle di verità (Truth Table, TT).
  - Espressione simbolica



## Dal circuito alla funzione logica



$$F = (A \text{ AND } B) \text{ OR } (B \text{ AND NOT}(C))$$

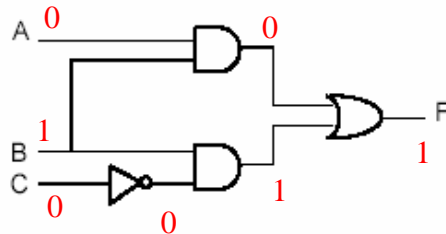

A	B	C	F
0	0	0	0
0	0	1	0
0	1	0	1
0	1	1	0
1	0	0	0
1	0	1	0
1	1	0	1
1	1	1	1



## Dall'espressione logica alla tabella della verità



- Data l'espressione:  $F = (A \text{ AND } B) \text{ OR } (B \text{ AND NOT}(C))$

Ricaviamo la tabella delle verità:

A	B	C	A and B	B and not(C)	F
0	0	0	0	0	0
0	0	1	0	0	0
0	1	0	0	1	1
0	1	1	0	0	0
1	0	0	0	0	0
1	0	1	0	0	0
1	1	0	1	1	1
1	1	1	1	0	1



## Dal circuito alla funzione logica



Esempio:

a b c	y
0 0 0	1
0 0 1	0
0 1 0	0
0 1 1	0
1 0 0	1
1 0 1	0
1 1 0	0
1 1 1	1

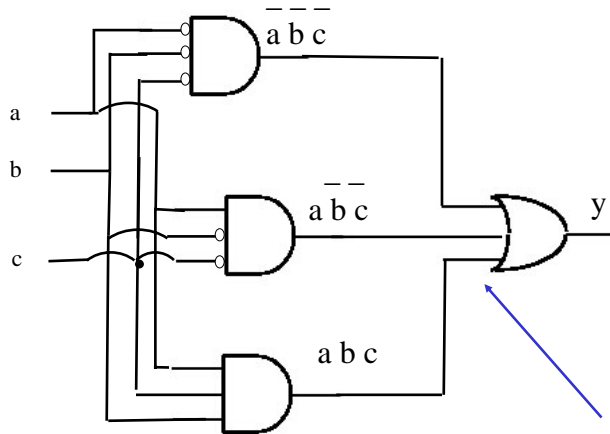

Implementazione circuitale possibile.  
Non è l'unica!

Funzione e tabella  
coincidono

$$y = a \bar{b} \bar{c} + a \bar{b} c + a b \bar{c}$$



## Sommario



Variabili ed operatori semplici.

Implementazione circuitale (porte logiche).

Dal circuito alla funzione.

**Algebra Booleana.**



## Concatenazione degli operatori



In assenza di parentesi, AND ha la priorità sull'OR ed il NOT su entrambi:

$$A + B \cdot C = A + (B \cdot C)$$

$$\text{NOT } A \cdot C = (\text{NOT}(A)) \cdot C = \bar{A}C$$



## Regole algebriche



Doppia Inversione	$\bar{\bar{x}} = x$	
	AND	OR
Identità	$1 \cdot x = x$	$0 + x = x$
Elemento nullo	$0 \cdot x = 0$	$1 + x = 1$
Idempotenza	$x \cdot x = x$	$x + x = x$
Inverso	$x \cdot \bar{x} = 0$	$x + \bar{x} = 1$
Commutativa	$x \cdot y = y \cdot x$	$x + y = y + x$
Associativa	$(x \cdot y) \cdot z = x \cdot (y \cdot z)$	$(x + y) + z = x + (y + z)$
	AND rispetto ad OR	OR rispetto ad AND
Distributiva	$x \cdot (y + z) = x \cdot y + x \cdot z$	$x + y \cdot z = (x + y) \cdot (x + z)$
Assorbimento	$x \cdot (x + y) = x$	$x + x \cdot y = x$
<b>De Morgan</b>	$\overline{xy} = \bar{x} + \bar{y}$	$\overline{x + y} = \bar{x} \cdot \bar{y}$

Si possono dimostrare sostituendo 0/1 alle variabili.





## Teoremi di De Morgan



De Morgan

$$\sim (x y) = \sim x + \sim y \quad \sim (x+y) = \sim x \sim y$$

$$\overline{\overline{xy}} = \overline{\overline{x} + \overline{y}}$$

$$\overline{\overline{x+y}} = \overline{\overline{x} \overline{y}}$$

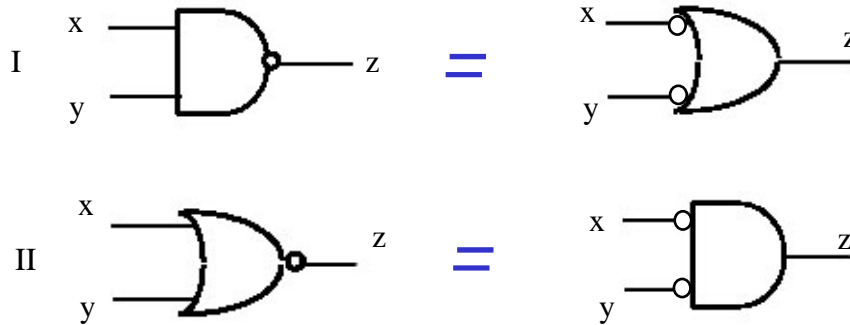

## Principio di dualità



- Nell'algebra di Boole vale il principio di dualità.
- Il duale di una funzione booleana si ottiene sostituendo AND ad OR, OR ad AND, gli 0 agli 1 e gli 1 agli 0.

Esempi:

Identità	$1 x = x$	$0 + x = x$
Elemento nullo	$0 x = 0$	$1 + x = 1$

- Le proprietà commutativa, distributiva, identità, inverso sono postulati: assunti veri per definizione.
- Le altre proprietà sono teoremi dimostrabili.



## Porte Universali



- Quale è il numero minimo di porte con cui è possibile implementare tutte le altre?
- Con la legge di De-Morgan riusciamo a passare da 3 a 2. es.: con NOT e AND (NAND) si ottiene OR:

$$\text{NOT}(\text{NOT}(A)\text{AND}(\text{NOT}(B))) = A \text{ OR } B$$

E' possibile usarne una sola?

- Sì, ad esempio la porta NAND, o la NOR che sono chiamate **porte universali**.



## Porta Universale NOR



- $\text{NOT } A = 0 \text{ NOR } A$
- $A \text{ OR } B = (A \text{ NOR } B) \text{ NOR } 0$
- $A \text{ AND } B = (A \text{ NOR } 0) \text{ NOR } (B \text{ NOR } 0)$

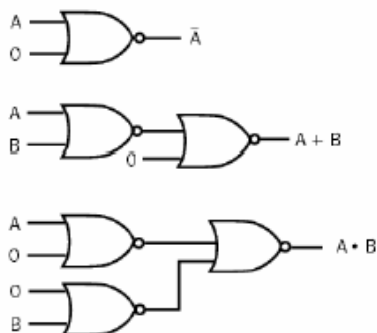



## Esercizi



Usare la sola porta NAND per realizzare AND, OR e NOT e disegnarne gli schemi logici

- Dimostrare le seguenti uguaglianze

$$A + \sim AB = A + B$$

$$(A + \sim B)(B + C) = AB + AC + \sim BC$$

usando le proprietà dell'algebra di Boole.

- Calcolare le TT per le seguenti funzioni

$$DA + AC + \sim B$$

$$A + B + C + D$$

$$\sim D \sim ABC + \sim DABC + \sim D \sim AB \sim C + \sim DAB \sim C$$

- Trasformare in funzioni equivalenti le seguenti

$$\sim(ABCD)$$

$$\sim(DA) + \sim(B + \sim C)$$



## Sommario



Variabili ed operatori semplici.

Implementazione circuitale (porte logiche).

Dal circuito alla funzione.

Algebra Booleana.