



Circuiti combinatori notevoli

Prof. Alberto Borghese
Dipartimento di Informatica
alberto.borghese@unimi.it

Università degli Studi di Milano

Riferimenti sul Patterson Hennessy: Sezione B3.



Sommario

Implementazione circuitale mediante PLA o ROM

Circuiti combinatori notevoli



Circuiti combinatori



- Circuiti logici digitali in cui le operazioni (logiche) dipendono solo da una combinazione degli input.
- Circuiti senza memoria. Ogni volta che si inseriscono in ingresso gli stessi valori, si ottengono le stesse uscite. Il risultato non dipende dallo stato del circuito.
- I circuiti combinatori descrivono delle funzioni Booleane. Queste funzioni si ottengono combinando tra loro (in parallelo o in cascata) gli operatori logici: **NOT, AND, OR**.
- Il loro funzionamento può essere descritto come **tabella della verità**.
- Come nelle funzioni algebriche, il risultato è aggiornato immediatamente dopo il cambiamento dell'input (si suppone il tempo di commutazione trascurabile, tempo di attesa prima di guardare l'output sufficientemente ampio per permettere a tutti i circuiti la commutazione).



Funzione come circuito



$$F = A B + B \bar{C}$$

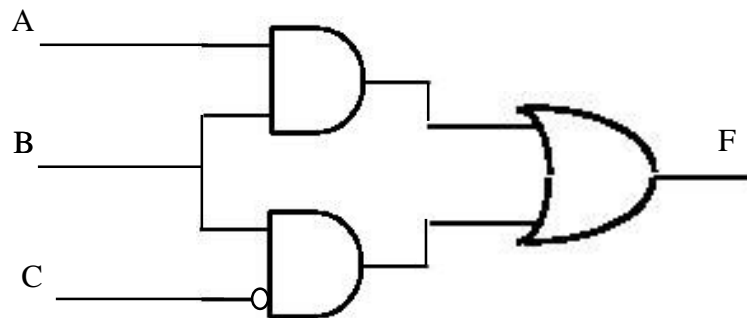

Le operazioni algebriche hanno un ordine di precedenza.



Razionale della prima forma canonica



$$F = A B + B \bar{C}$$

A B C	F
0 0 0	0
0 0 1	0
0 1 0	1
0 1 1	0
1 0 0	0
1 0 1	0
1 1 0	1
1 1 1	1

$$F = \bar{A}\bar{B}\bar{C} + \bar{A}B\bar{C} + A\bar{B}C$$

$$F = 1$$

iff

$$A = 0 \ B = 1 \ C = 0$$

OR

$$A = 1 \ B = 1 \ C = 0$$

OR

$$A = 1 \ B = 1 \ C = 1$$



La prima forma canonica



- Esiste un metodo per ricavare automaticamente un circuito che implementi una tabella di verità?
- Una **forma canonica** garantisce di poter realizzare una qualunque tabella di verità con solo due livelli di porte OR, AND e NOT:
- Somme di Prodotti (SOP) è la prima forma canonica:

A B C	F
0 0 0	0
0 0 1	0
0 1 0	1 m_2
0 1 1	0
1 0 0	0
1 0 1	0
1 1 0	1 m_6
1 1 1	1 m_7

$$F = m_2 + m_6 + m_7$$

mintermini

$$F = \bar{A}\bar{B}\bar{C} + A\bar{B}\bar{C} + A\bar{B}C$$



Livelli di astrazione intermedi: anche per le linee

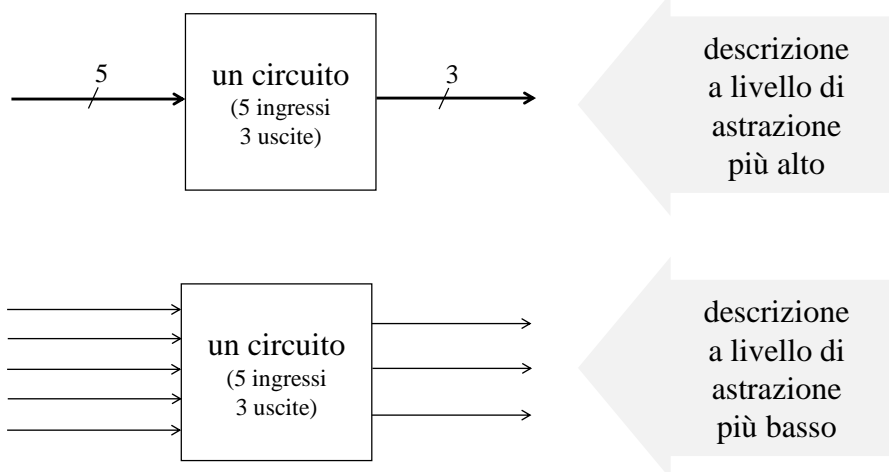

Tipi di circuiti che implementano le SOP



In generale abbiamo funzioni logiche booleane multi-input / multi-output.

I circuiti complessi si ottengono collegando «piccoli» blocchi funzionali, dove ciascun blocco implementa una funzione logica.

- Logica distribuita.
- PLA: Programmable Logic Array: matrici regolari AND e OR in successione, personalizzabili dall'utente.
- ROM: Read Only Memory circuiti ad hoc che implementano una particolare funzione in modo irreversibile.



Logica distribuita

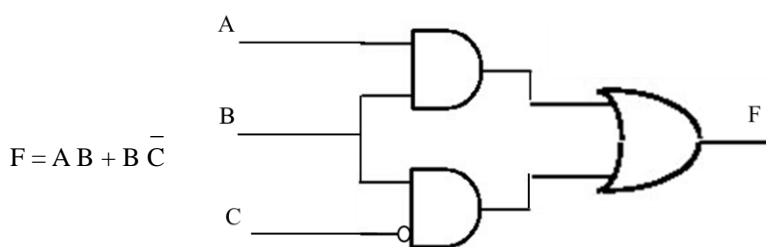
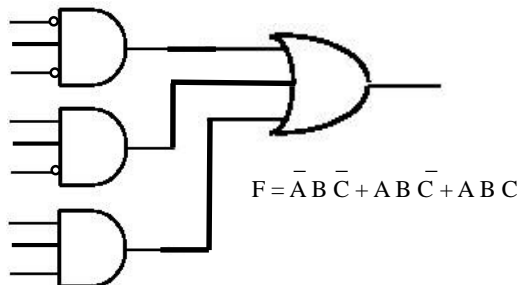

PLA (Programmable Logical Array)



- Architettura a 2 livelli:
 - Un primo livello di AND
 - Un secondo livello di OR

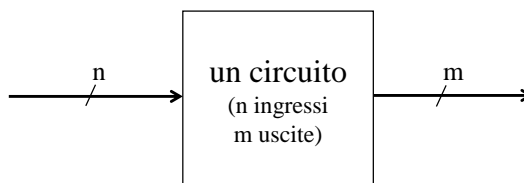

- La matrice degli AND ha n linee di ingresso: ciascuna porta ha in ingresso le **n linee** e il loro complemento.
- L'utente specifica per ogni porta AND a disposizione se la linea in ingresso entra direttamente o dopo una negazione.
 - Crea la matrice dei mintermini, bruciando in ingresso alle porte AND le linee che non servono.
- Le uscite della matrice AND entrano nella matrice OR programmata come la precedente per ottenere l'OR dei mintermini della funzione.
 - Si utilizza una porta OR per ogni funzione calcolata (m OR per **m linee** di uscita)



Struttura di una PLA

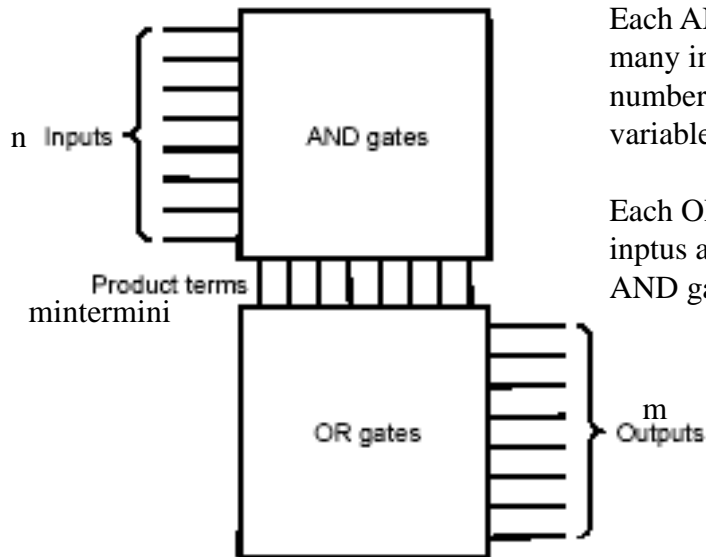

Each AND has as many inputs as the number of input variables

Each OR has as many inputs as the number of AND gates



Esempio di PLA



- Realizzare con un PLA la funzione descritta dalla seguente TT

	X_0	X_1	X_2	Z_0	Z_1
$m_1 \rightarrow$	0	0	0	0	0
	0	0	1	1	0
	0	1	0	1	0
	0	1	1	0	1
	1	0	0	1	0
$m_6 \rightarrow$	1	0	1	0	1
$m_7 \rightarrow$	1	1	0	0	1
	1	1	1	1	1

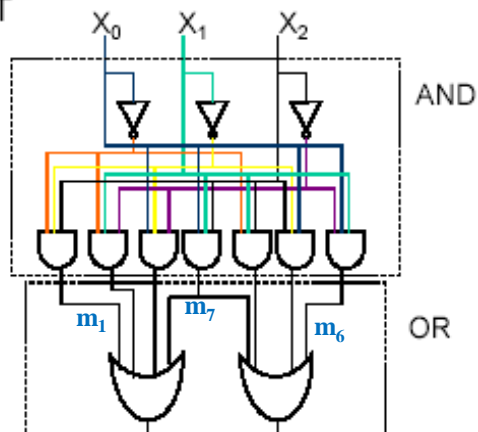

$$Z_0 = \overline{X_0} \overline{X_1} \overline{X_2} + \overline{X_0} X_1 \overline{X_2} + X_0 \overline{X_1} \overline{X_2} + X_0 X_1 X_2 = m_1 + m_2 + m_4 + m_7$$

$$Z_1 = \overline{X_0} X_1 X_2 + X_0 \overline{X_1} X_2 + X_0 X_1 \overline{X_2} + X_0 X_1 X_2 = m_3 + m_5 + m_6 + m_7$$



Complessità e cammino critico

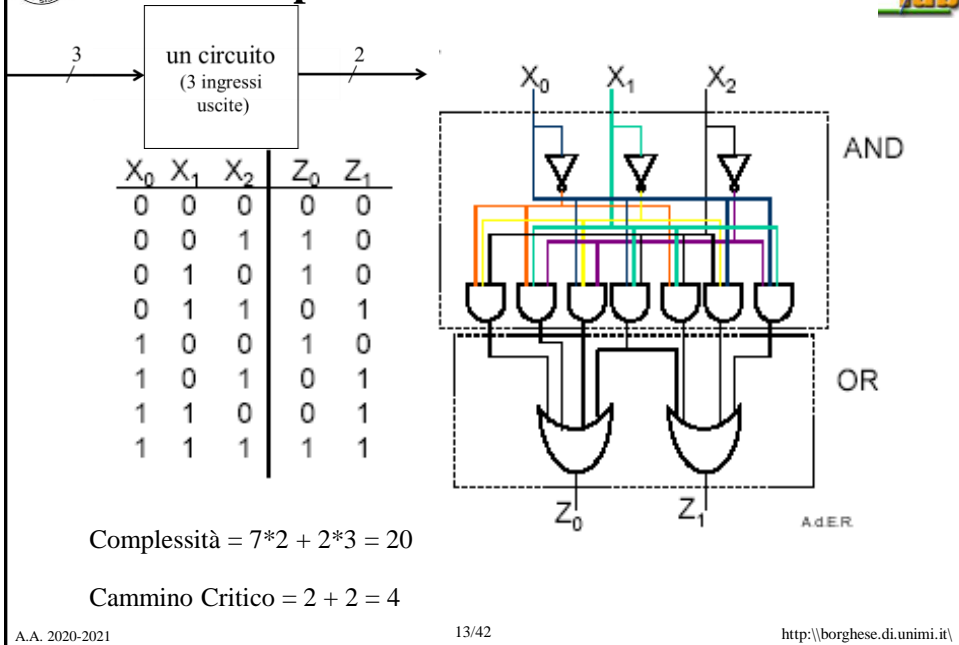

Decodificatore (decoder)



- E' caratterizzato da n linee di input e 2^n linee di output

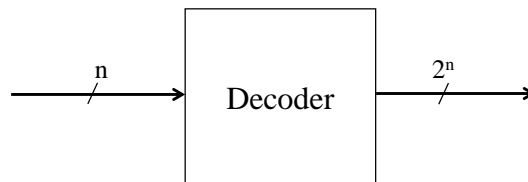

- il numero binario espresso dalla configurazione delle linee di input è usato per asserire la **sola** linea di output di ugual indice (tutte le altre portano 0)
- es.: con 4 linee di input e 16 di output (da 0 a 15), se in ingresso arriva il valore 0110 (6 decimale), in uscita si alza la linea di indice 5 (la sesta!), tutte le altre hanno valore 0
- utilizzato per indirizzare la memoria ad esempio (cf. ROM)



Decoder a 2 ingressi



Tabella della verità

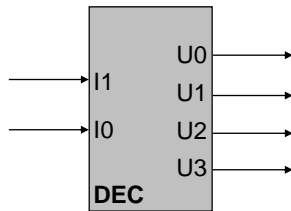

I1	I0	U0	U1	U2	U3
0	0	1	0	0	0
0	1	0	1	0	0
1	0	0	0	1	0
1	1	0	0	0	1



Decoder a 2 ingressi: realizzazione



I1	I0	U0	U1	U2	U3
0	0	1	0	0	0
0	1	0	1	0	0
1	0	0	0	1	0
1	1	0	0	0	1



Tabella della verità

I1	I0	U0	U1	U2	U3
0	0	1	0	0	0
0	1	0	1	0	0
1	0	0	0	1	0
1	1	0	0	0	1



Decoder a 3 ingressi

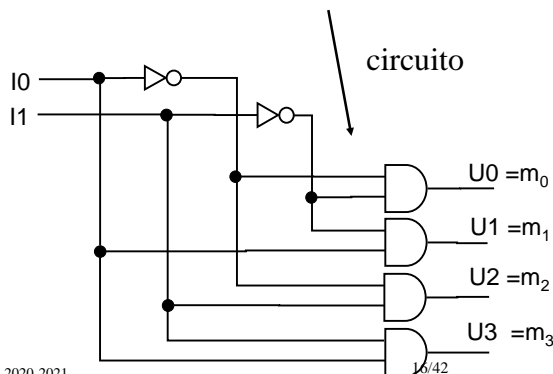
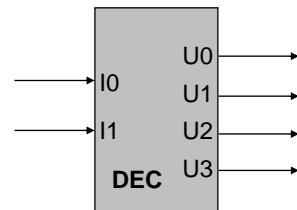
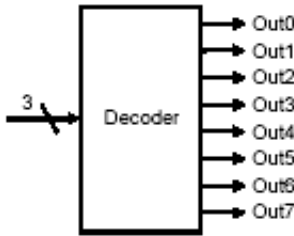

a. A 3-bit decoder

A	B	C	U ₀	U ₁	U ₂	U ₃	U ₄	U ₅	U ₆	U ₇
0	0	0	1	0	0	0	0	0	0	0
0	0	1	0	1	0	0	0	0	0	0
0	1	0	0	0	1	0	0	0	0	0
0	1	1	0	0	0	1	0	0	0	0
1	0	0	0	0	0	0	1	0	0	0
1	0	1	0	0	0	0	0	1	0	0
1	1	0	0	0	0	0	0	0	1	0
1	1	1	0	0	0	0	0	0	0	1

Le funzioni di uscita sono 2^n per n input:

$$U_0 = \sim A \sim B \sim C$$

...

$$U_7 = A B C$$

$$U_j = m_j$$

I mintermini sono AND a 3 ingressi



Valutazione del decoder a 3 ingressi

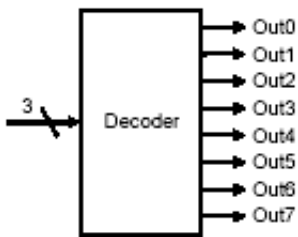

a. A 3-bit decoder

A	B	C	U ₀	U ₁	U ₂	U ₃	U ₄	U ₅	U ₆	U ₇
0	0	0	1	0	0	0	0	0	0	0
0	0	1	0	1	0	0	0	0	0	0
0	1	0	0	0	1	0	0	0	0	0
0	1	1	0	0	0	1	0	0	0	0
1	0	0	0	0	0	0	1	0	0	0
1	0	1	0	0	0	0	0	1	0	0
1	1	0	0	0	0	0	0	0	1	0
1	1	1	0	0	0	0	0	0	0	1

Le funzioni di uscita sono 2^n per n input:

$$U_0 = \sim A \sim B \sim C$$

...

$$U_7 = A B C$$

$$U_j = m_j$$

I mintermini sono AND a 3 ingressi

Complessità: $8 \cdot 2 = 16$

Cammino critico: 2

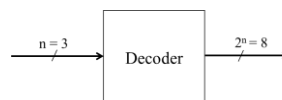



Rappresentazione circuitale mediante ROM



- Read Only Memory, memoria di sola lettura.
Funge anche da modulo combinatorio a uscita multipla.
- n linee di ingresso, m linee di uscita (ampiezza)
a ciascuna delle 2^n (altezza) configurazioni di ingresso (parole di memoria) è associata permanentemente una combinazione delle m linee di uscita.
- l'input seleziona la parola da leggere di m bit, che appare in uscita
- L'input funziona da **indice** all'interno della ROM. Viene realizzato con un decoder n-a- 2^n seguito da una matrice di m porte OR.



ROM - esempio



X_0	X_1	X_2	Z_0	Z_1
0	0	0	0	0
0	0	1	1	0
0	1	0	1	0
0	1	1	0	1
1	0	0	1	0
1	0	1	0	1
1	1	0	0	1
1	1	1	1	1

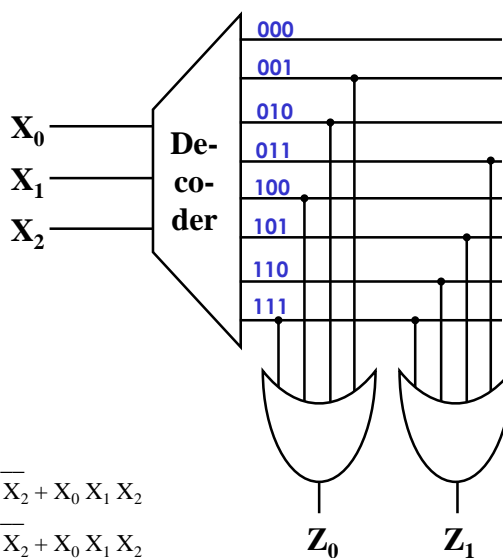

$$Z_0 = \overline{X_0} \overline{X_1} X_2 + \overline{X_0} X_1 \overline{X_2} + X_0 \overline{X_1} \overline{X_2} + X_0 X_1 X_2$$

$$Z_1 = \overline{X_0} X_1 X_2 + X_0 \overline{X_1} X_2 + X_0 X_1 \overline{X_2} + X_0 X_1 X_2$$



EEPROM



X_0	X_1	X_2	Z_0	Z_1
0	0	0	0	0
0	0	1	1	0
0	1	0	1	0
0	1	1	0	1
1	0	0	1	0
1	0	1	0	1
1	1	0	0	1
1	1	1	1	1

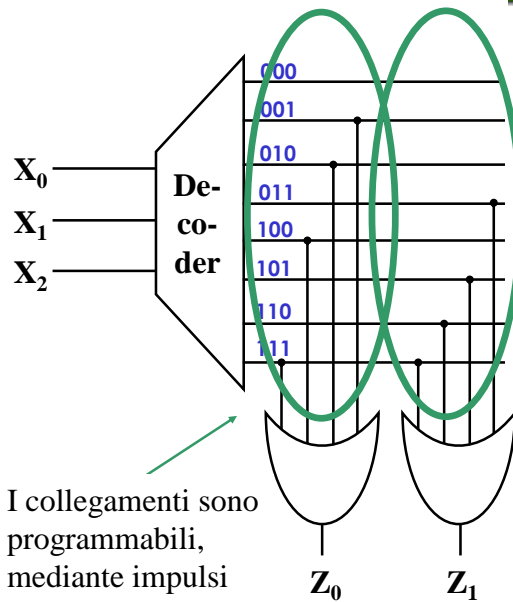

Valutazione ROM



X_0	X_1	X_2	Z_0	Z_1
0	0	0	0	0
0	0	1	1	0
0	1	0	1	0
0	1	1	0	1
1	0	0	1	0
1	0	1	0	1
1	1	0	0	1
1	1	1	1	1

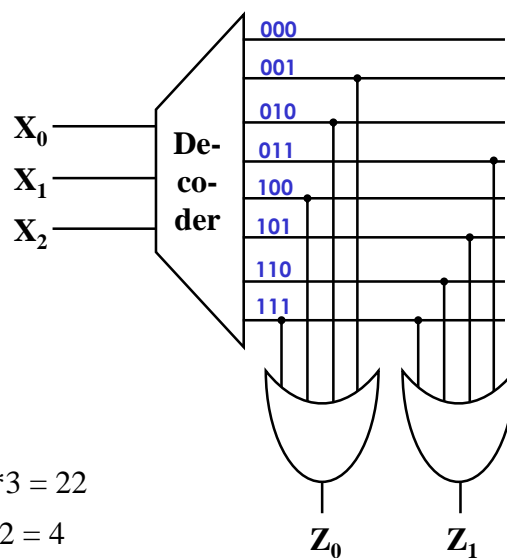



Confronto PLA / ROM

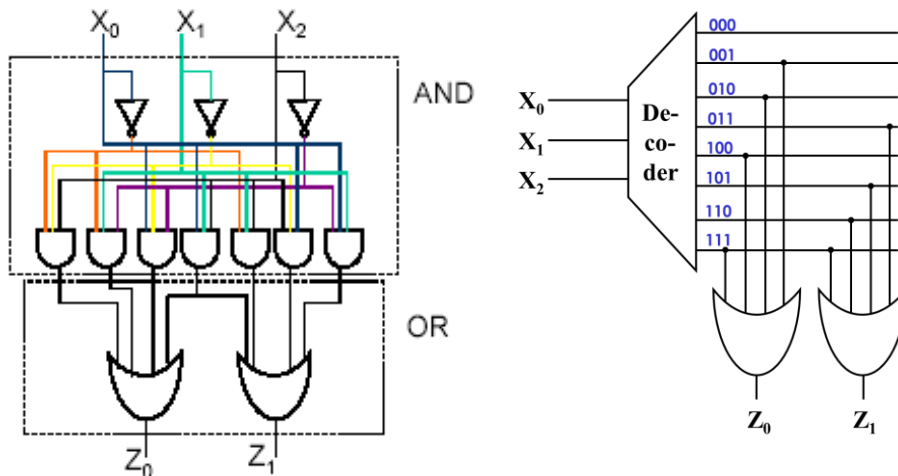

Confronto PLA - ROM



ROM – fornisce un'uscita per ognuna delle combinazioni degli ingressi. Decoder con 2^n uscite, dove n è il numero di variabili in ingresso alla ROM. Crescita esponenziale delle uscite. Approccio più generale. Può implementare una qualsiasi funzione, dato un certo numero di input e output.

PLA – contiene solamente i mintermini in uscita al primo stadio. Il loro numero cresce meno che esponenzialmente.

E' più veloce una PLA o una ROM? Valutare in termini di cammino critico.

FPGA – Maggiore libertà. E' costituita da celle: moduli di PLA. E' una rete di strutture a 2 livelli.



Esercizi sulla PLA



Realizzare mediante PLA con 3 ingressi con il numero adeguato di linee interne:

- la funzione maggioranza.
- la funzione che vale 1 se e solo se 1 solo bit di ingresso vale 1
- un decoder
- la funzione che vale 0 se l'input è pari, 1 se dispari
- la funzione che calcola i multipli di 3 (con 4 ingressi)

Realizzare le stesse funzioni con una ROM o con logica distribuita e operare un confronto. Fare una valutazione comparata in termini di complessità e cammino critico.



Sommario



Implementazione circuitale mediante PLA o ROM.

Circuiti combinatori notevoli.



Porta XOR



a	b	y
0	0	0
0	1	1
1	0	1
1	1	0

$$\text{SOP: } y = \bar{a}b + a\bar{b}$$

OR esclusivo
Disuguaglianza di 2 ingressi

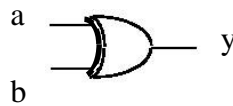

Complessità e cammino critico di 1 porta logica

$$y = a \oplus b$$



Uscite indifferenti di un tabella delle verità



X = "don't care" = {0,1} a sconda di quello che conviene.

A	B	F
0	0	0
0	1	X
1	0	0
1	1	1

Ho 2 possibilità:

1) $X = 0$

$$F = A B$$

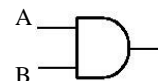

2) $X = 1$

$$F = A B + A \bar{B} = B$$



Diminuisce il numero di porte e si accorcia il cammino critico.



Codificatore (encoder)



- E' caratterizzato da n linee di input e $\text{ceil}(\log_2 n)$ linee di output

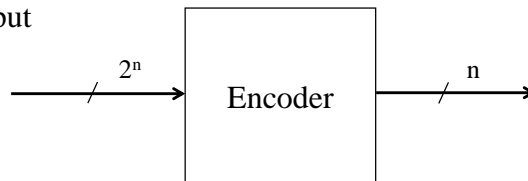

- Una sola linea di ingresso può essere attiva.
- il numero binario espresso dalla configurazione delle linee di output rappresenta la linea di ingresso attiva.
- es.: con 16 linee di input e 4 di output, se in ingresso arriva il valore 0000 0100 0000 0000, in uscita leggiamo il numero 10.



La funzione encoder



ABCD	$Y_1 Y_2$
0000	X X
0001	0 0
0010	0 1
0011	X X
0100	1 0
0101	X X
0110	X X
0111	X X
1000	1 1
1001	X X
1010	X X
1011	X X
1100	X X
1101	X X
1110	X X
1111	X X

Codifica quattro linee in ingresso: 0,1,2,3

Suppongo $X = 0$

$$Y_1 = \overline{A}BCD + A\overline{B}CD = CD (A \oplus B)$$

$$m_4 + m_8$$

$$Y_2 = \overline{A}BC\overline{D} + A\overline{B}C\overline{D} = \overline{B}C\overline{D} (A \oplus C)$$

$$m_2 + m_8$$

Complessità: $2 \cdot 3 + 1 = 7$

Complessità circuito semplificato: 3

Cammino critico: $2 + 1 = 3$

Cammino critico circuito semplificato: 2

Si può fare di meglio?

Come è conveniente impostare le X?



La funzione encoder: ottimizzazione



ABCD	$Y_1 Y_2$
0000	0 X
0001	0 0
0010	0 1
0011	0 X
0100	1 0
0101	1 X
0110	1 X
0111	1 X
1000	1 1
1001	1 X
1010	1 X
1011	1 X
1100	0 X
1101	0 X
1110	0 X
1111	0 X

Consideriamo la prima funzione, Y_1

$$Y_1 = \overline{A}BCD + A\overline{B}CD = \overline{C}D (A \oplus B)$$

$$m_4 + m_8$$

Specifichiamo in modo opportuno i valori di uscita indifferenti, X

$$Y_1 = \overline{A}B\overline{C}D + \overline{A}BCD + A\overline{B}CD + A\overline{B}C\overline{D} +$$

$$\overline{A}B\overline{C}D + \overline{A}BCD + A\overline{B}CD + A\overline{B}C\overline{D} +$$

$$\overline{A}BCD = (A \oplus B)$$

Complessità: 1

Cammino critico: 1



Multiplexer (selettore)



- Ha la funzione di un sistema di semafori.
- E' caratterizzato da:
 - n linee di input (data) - $\{x_i\}$
 - k linee di controllo (selezione) - $\{S\}$.
 - 1 linea di output.
- In base alla linea di controllo viene connessa all'uscita la linea di ingresso selezionata.

Quante linee di controllo, k, servono?

$$k = \text{ceil}(\log_2 n)$$

Esempio: con 4 linee di input (da 0 a 3), se sulle linee di controllo c'è 11, in uscita si avrà il valore presente sulla linea 3

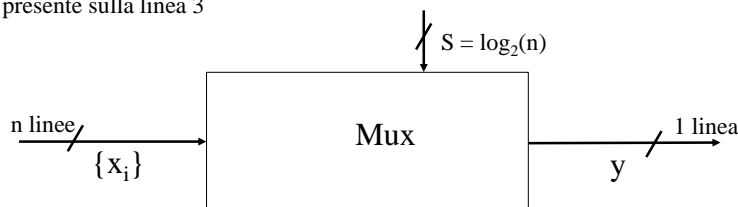



AND come semaforo (interruttore)



Il segnale di selezione S, “apre” la porta opportuna, cioè chiude il cammino opportuno.

L'AND funziona da porta di uscita (da semaforo)

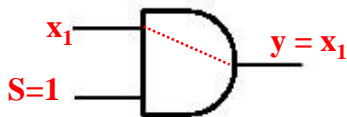

S	x_1	y
0	0	0
0	1	0
1	0	0
1	1	1



Multiplexer



S	x_0	x_1	y
0	0	0	0
0	0	1	0
0	1	0	1
0	1	1	1
1	0	0	0
1	0	1	1
1	1	0	0
1	1	1	1

Il circuito deve portare in uscita il contenuto della linea x_0 o x_1 a seconda del valore di S

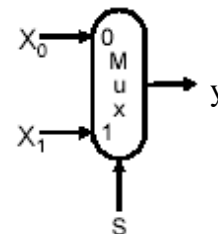
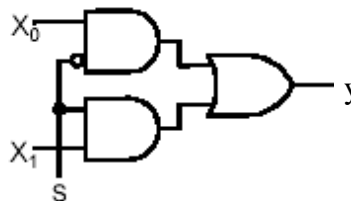



Sintesi della funzione Mux



	S	x_0	x_1	y
$y=x_0$	0	0	0	0
	0	0	1	0
	0	1	0	1
	0	1	1	1
$y=x_1$	1	0	0	0
	1	0	1	1
	1	1	0	0
	1	1	1	1

$$\text{SOP: } y = \bar{S} x_0 \bar{x}_1 + \bar{S} x_0 x_1 + S \bar{x}_0 x_1 + S x_0 x_1$$

$$= \bar{S} x_0 + S x_1 \quad \text{cvd}$$

Il mux si comporta come interruttore:

If (S == 1) then
 $y = x_1$
 If (S == 0) then
 $y = x_0$

Complessità: 3
 Cammino critico: 2

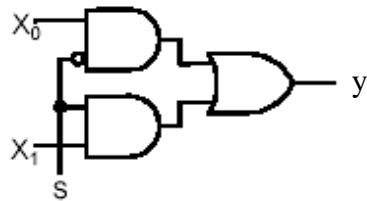

Mux a n vie.

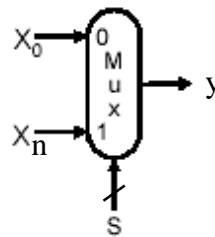
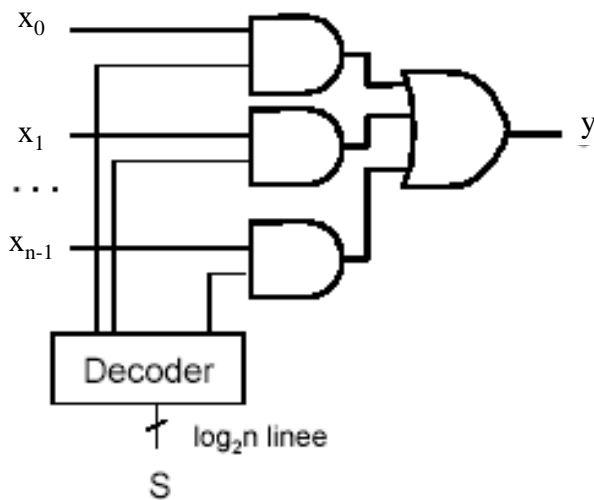

Una sola linea alla volta viene aperta dal segnale S. **Le linee sono mutuamente esclusive.**



Complessità di un Mux a 8 vie

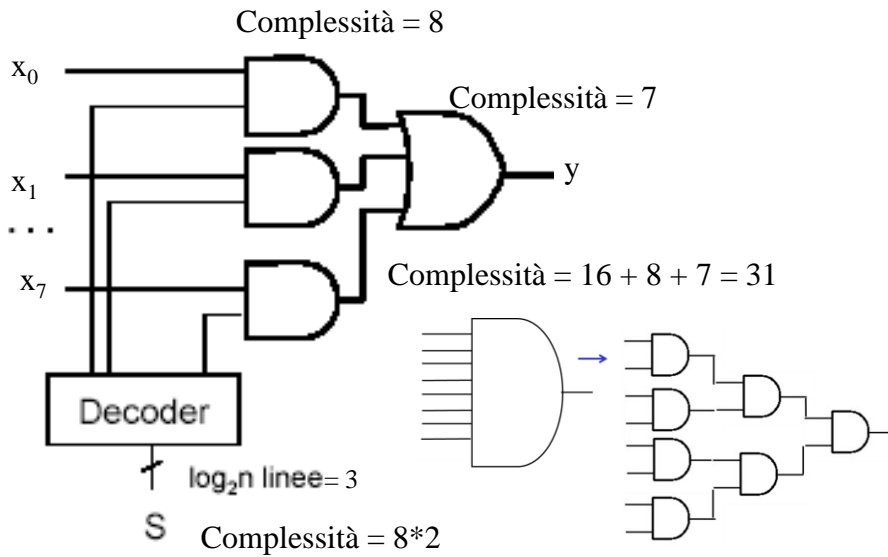

Cammino critico di un Mux a 8 vie

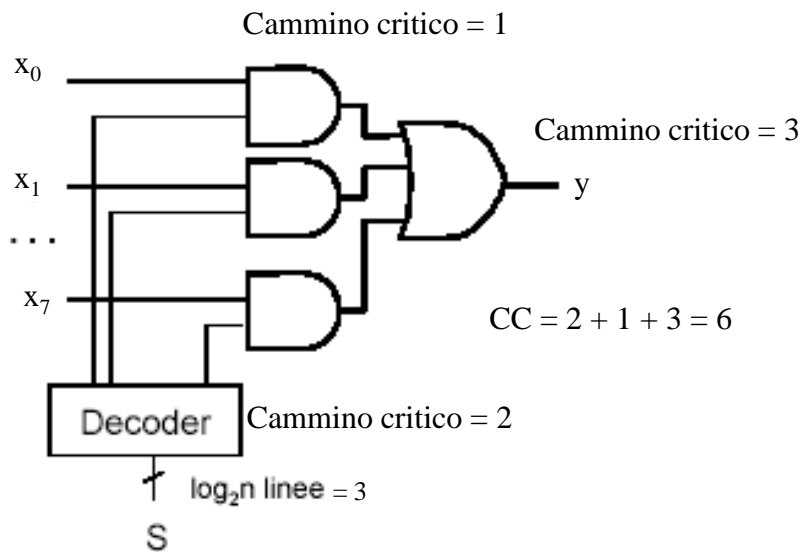



Il Multiplexer a un ingresso di selezione è l' "if" dell'hardware



- Software

```
if A>B
  then y=A
  else y=B
```

**Esecuzione
condizionata**

- Hardware

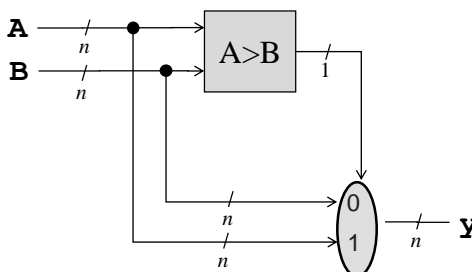

Il Multiplexer a un ingresso di selezione è l' "if" dell'hardware



- Software

```
if A>B
  then y=g(X)
  else y=f(X)
```

- Hardware

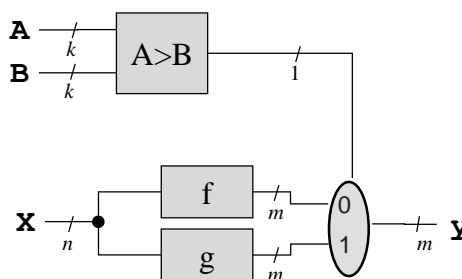

Entrambe le funzioni
sono calcolate, ma solo
un risultato alla volta
viene usato!



Comparatore



- E' caratterizzato da:
 - 1 numero su n bit in ingresso, A
 - 1 numero su n bit in ingresso, B
 - 1 uscita

$$C_k = \overline{A_k} \oplus B_k$$

A_0	B_0	C_0	A_1	B_1	C_1
0	0	1	0	0	1
0	1	0	0	1	0
1	0	0	1	0	0
1	1	1	1	1	1

...

$$C = C_0 C_1 \dots C_{n-1}$$



Sommario



Implementazione circuitale mediante PLA o ROM.

Circuiti combinatori notevoli.