



Latch sincroni e flip-flop

Prof. Alberto Borghese
Dipartimento Informatica
borgnese@di.unimi.it

Università degli Studi di Milano

Riferimento Patterson: sezioni B.7 & B.8.



Sommario

Latch sincroni SR

Latch sincroni D

Flip-flop



Latch asincrono SC (o SR)

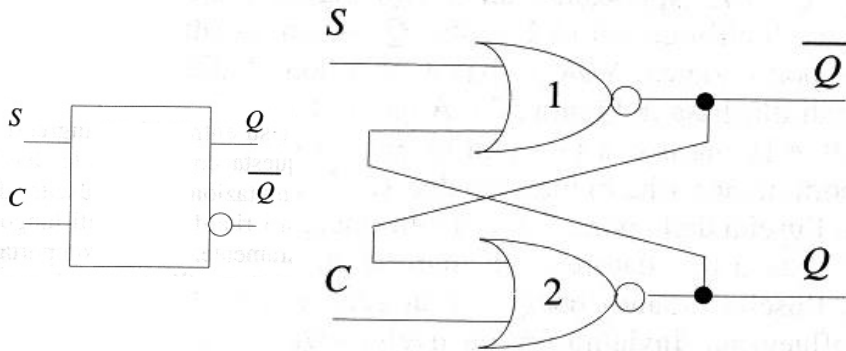

Una coppia di porte NOR retro-azionate può memorizzare un bit.



Il latch SC sincrono

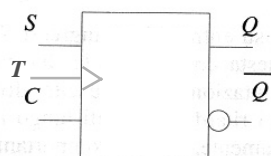
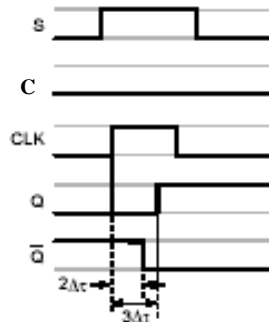
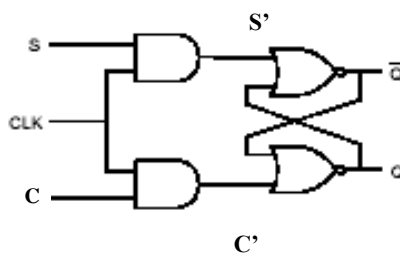

Si inserisce un AND tra il clock e gli ingressi.
Solo quando il clock è alto i “cancelli”
rappresentati dagli AND fanno passare gli input
(collegano l'altro ingresso dell'AND con
l'uscita). Cancelli di abilitazione del latch.



T	Q	S	C	Q*
0	0	0	0	0
0	0	0	1	0
0	0	1	0	0
0	0	1	1	0
0	1	0	0	1
0	1	0	1	1
0	1	1	0	1
0	1	1	1	1
1	0	0	0	0
1	0	0	1	0
1	0	1	0	1
1	0	1	1	X
1	1	0	0	1
1	1	0	1	0
1	1	1	0	1
1	1	1	1	X

Tabella della verità e tabella di transizione



TQ	SC = 00	SC = 01	SC = 10	SC = 11
00	0	0	0	0
01	1	1	1	1
10	0	0	1	X
11	1	0	1	X

$$Q^* = f(S, C, Q, T)$$



Tabella delle transizioni

$$Q^* = f(S, C, Q, T)$$



TQ	SC = 00	SC = 01	SC = 10	SC = 11
00	0	0	0	0
01	1	1	1	1
10	0	0	1	X
11	1	0	1	X

Q è l'uscita del latch: **stato presente**.

Q* è il valore dell'uscita al tempo successivo: **stato prossimo**.



T	Q	S	C	Q*
0	0	0	0	0
0	0	0	1	0
0	0	1	0	0
0	0	1	1	0
0	1	0	0	1
0	1	0	1	1
0	1	1	0	1
0	1	1	1	1
1	0	0	0	0
1	0	0	1	0
1	0	1	0	1
1	0	1	1	X = 0
1	1	0	0	1
1	1	0	1	0
1	1	1	0	1
1	1	1	1	X = 0

Tabella della verità - I



$$Q^* = f(S, C, Q, T)$$

TQ	SC = 00	SC = 01	SC = 10	SC = 11
00	0	0	0	0
01	1	1	1	1
10	0	0	1	X
11	1	0	1	X

$$Q^* = \overline{TQSC} + \overline{TQSC} + \overline{TQSC} + \overline{TQSC} + \overline{TQSC} + \overline{TQSC} + \overline{TQSC} + \overline{TQSC}$$

$$= \overline{TQC} + \overline{TQSC} + \overline{TQC} + \overline{TSC} =$$

$$= \overline{TQ} + \overline{TQSC} + \overline{TSC} =$$

$\overline{TQ} + \overline{T(QSC + SC)}$
 Status quo (Memory) : Cambia valore di uscita



T	Q	S	C	Q*
0	0	0	0	0
0	0	0	1	0
0	0	1	0	0
0	0	1	1	0
0	1	0	0	1
0	1	0	1	1
0	1	1	0	1
0	1	1	1	1
1	0	0	0	0
1	0	0	1	0
1	0	1	0	1
1	0	1	1	X = 1
1	1	0	0	1
1	1	0	1	0
1	1	1	0	1
1	1	1	1	X = 1

Tabella della verità - II



$$Q^* = f(S, C, Q, T)$$

TQ	SC = 00	SC = 01	SC = 10	SC = 11
00	0	0	0	0
01	1	1	1	1
10	0	0	1	X
11	1	0	1	X

$$Q^* = \overline{TQSC} + \overline{TQSC} + \overline{TQSC} + \overline{TQSC} + \overline{TQSC} + \overline{TQSC} + \overline{TQSC} + \overline{TQSC}$$

$$\overline{TQSC} + \overline{TQSC} + \overline{TQSC} =$$

$$= \overline{TQC} + \overline{TQSC} + \overline{TQC} + \overline{TQS} + \overline{TQS} =$$

$$= \overline{TQ} + \overline{TQSC} + \overline{TQS} + \overline{TQS} = \overline{TQ} + \overline{T(QSC + S)}$$

Cf. Latch asincrono
 Status quo (Memory) : Cambia valore di uscita



Sommario



Latch sincroni SR

Latch sincroni D

Flip-flop



Latch D sincrono



Memorizza il valore presente all'ingresso dati quando il clock è alto.

```
if clk = 1
  then
    Q* = D
  else
    Q* = Q
```

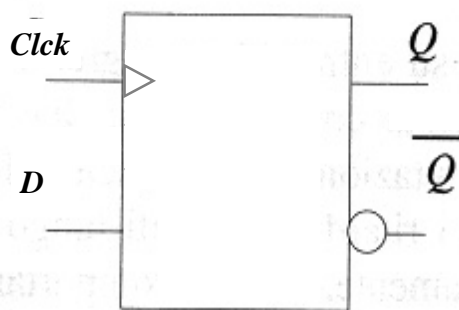

Latch-D



La struttura del latch D



Tabella delle transizioni

$$Q^* = f(T, Q, D)$$

TQ	D = 0	D = 1
00	0	0
01	1	1
11	0	1
10	0	1

La funzione logica corrispondente è:

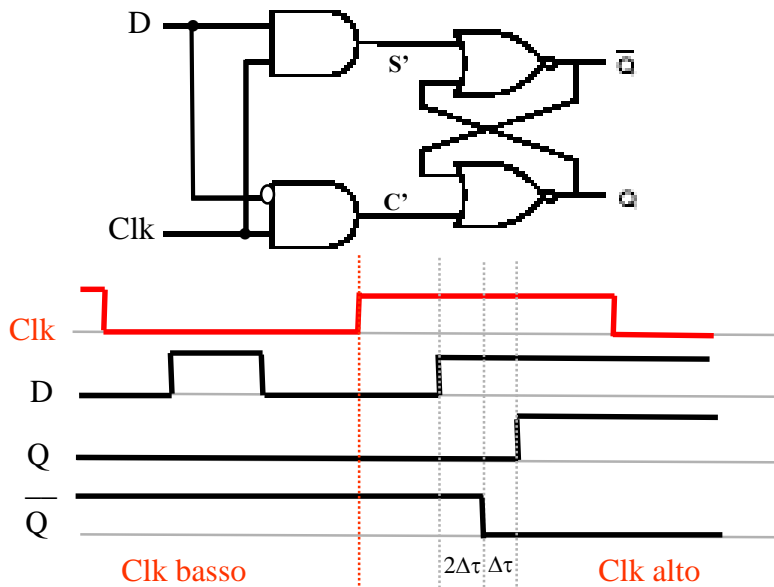
$$Q^* = TD + \bar{T}Q$$

$Q^* = D$

Status quo

Q è l'uscita del latch: **stato presente**.

Q* è il valore dell'uscita al tempo successivo: **stato prossimo**.



Tabella della verità

$$Q^* = f(T, Q, D)$$

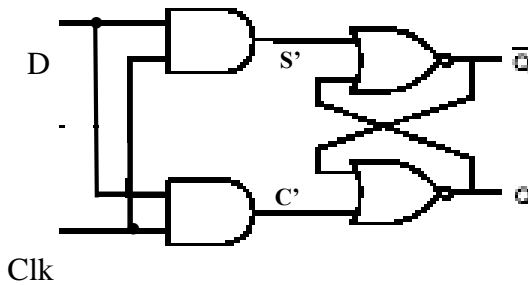

T	D	Q	Q*
0	0	0	0
0	0	1	1
0	1	0	0
0	1	1	1
1	0	0	0
1	0	1	0
1	1	0	1
1	1	1	1

$$Q^* = \bar{T}\bar{D}Q + \bar{T}DQ + T\bar{D}\bar{Q} + TDQ =$$

$$= \bar{T}Q + TD$$

Status quo

$$Q^* = D$$



Elemento di memoria

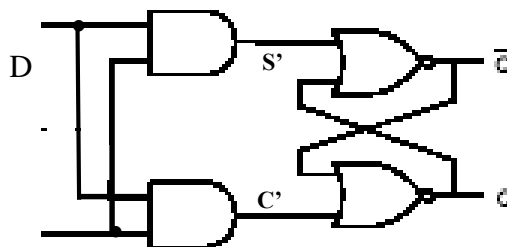

T = segnale di scrittura – Write – attivo alto

$$Q^* = \bar{T}\bar{D}Q + \bar{T}DQ + T\bar{D}\bar{Q} + TDQ =$$

$$= \bar{T}Q + TD$$

Status Quo
(memory)

$$Q^* = D$$

(write)

Se T = 1, scrivo D

Se T = 0, mantiene il dato in memoria



Sommario



Latch sincroni SR

Latch sincroni D

Flip-flop



I bistabili



- Elementi di memoria (latch)
- “Cancelli” (flip-flop)

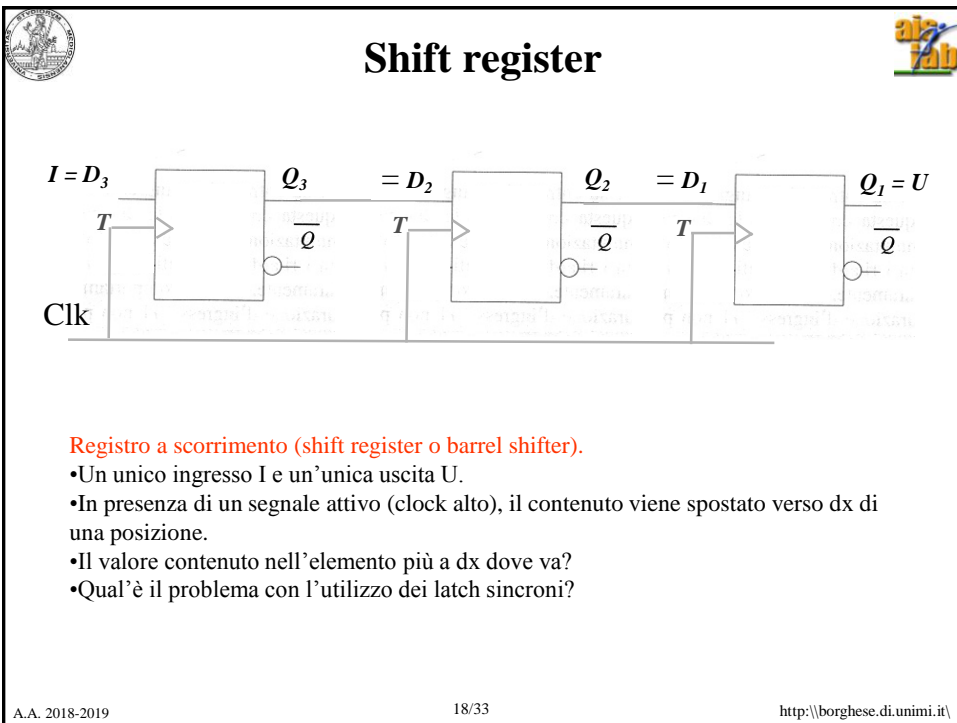
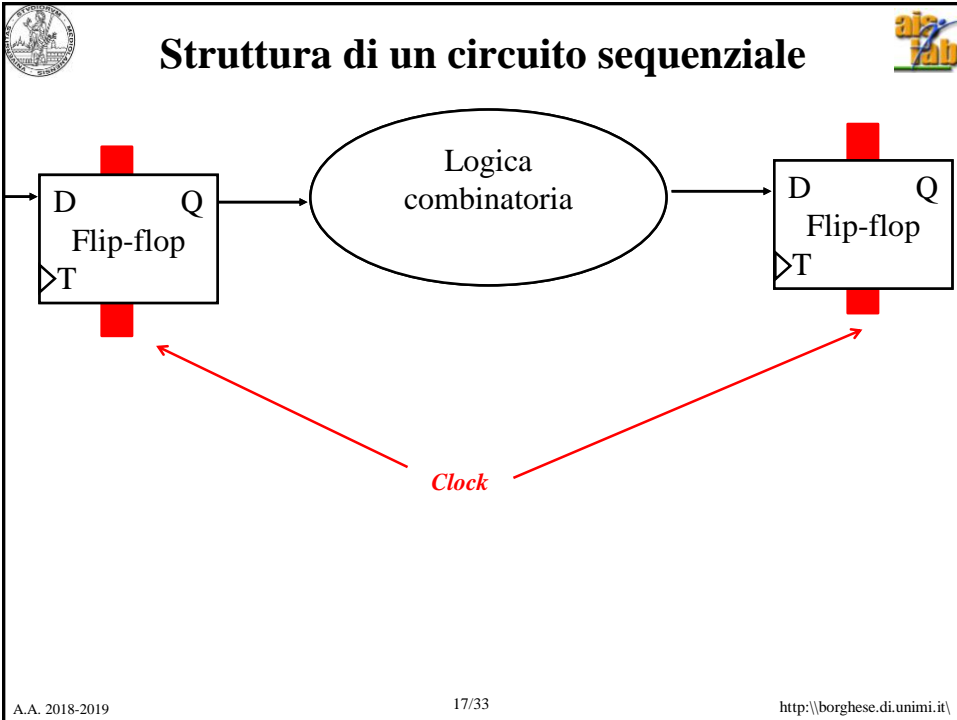



Shift register con i latch (i problemi)

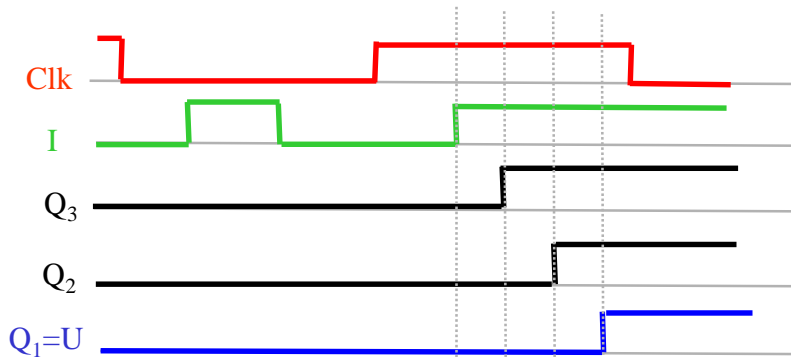
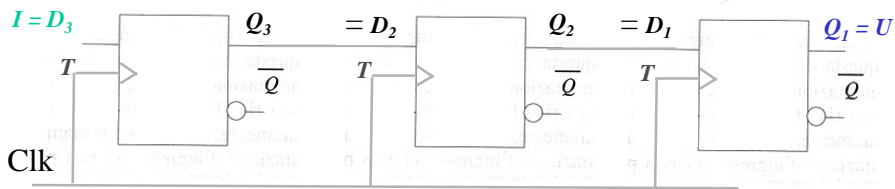

Dispositivo di sincronizzazione

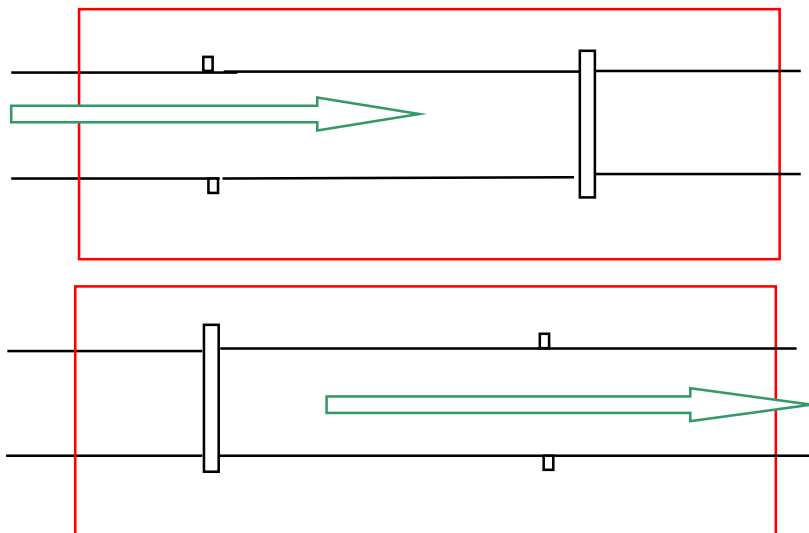



Flip-flop

Dispositivi attivi sul fronte (di salita o discesa) del clock (edge sensitive): il loro stato (uscita) può commutare solo in corrispondenza della transizione alto->basso o basso->alto del clock.

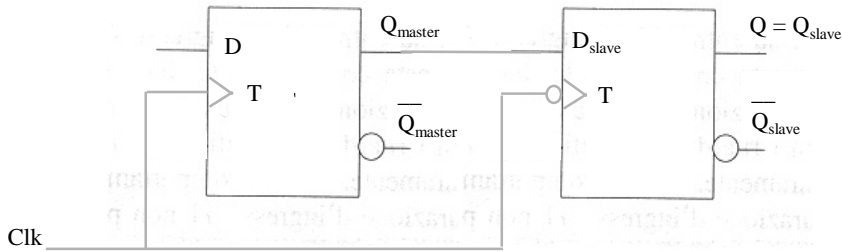

Configurazione Master-Slave



Flip-flop D

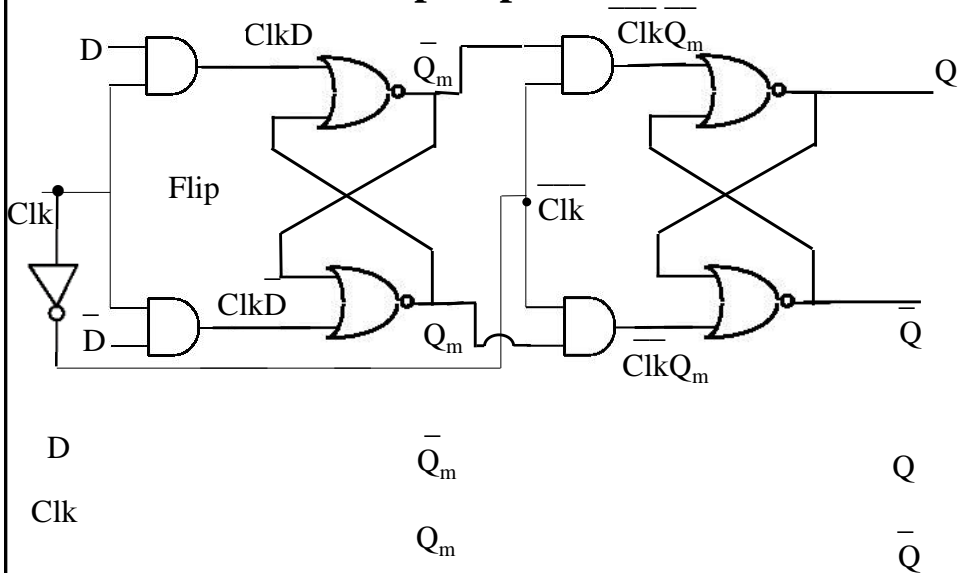

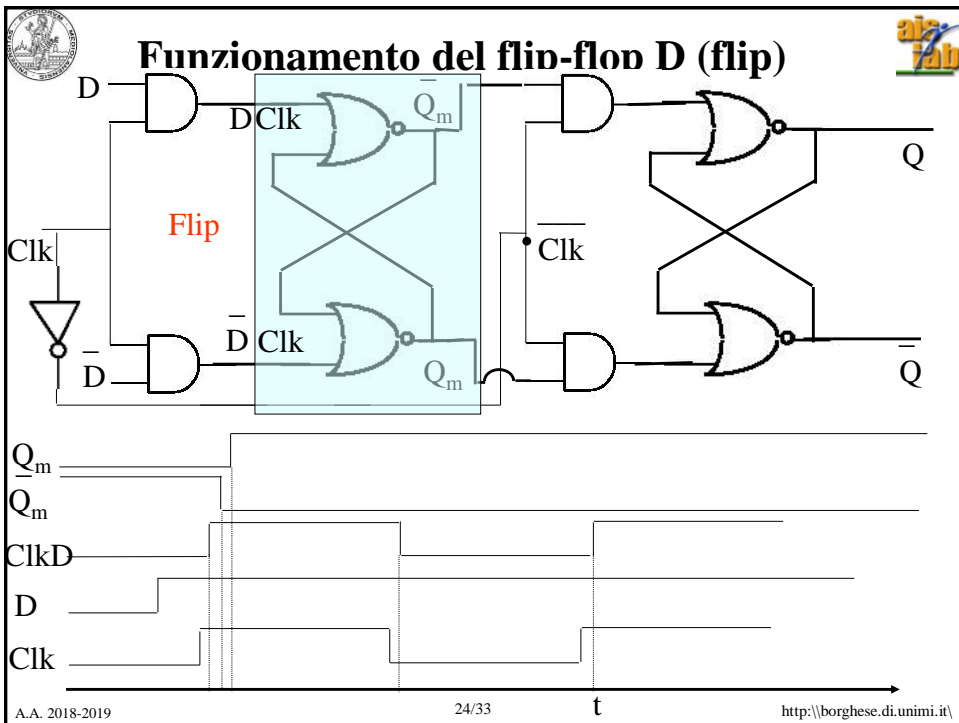
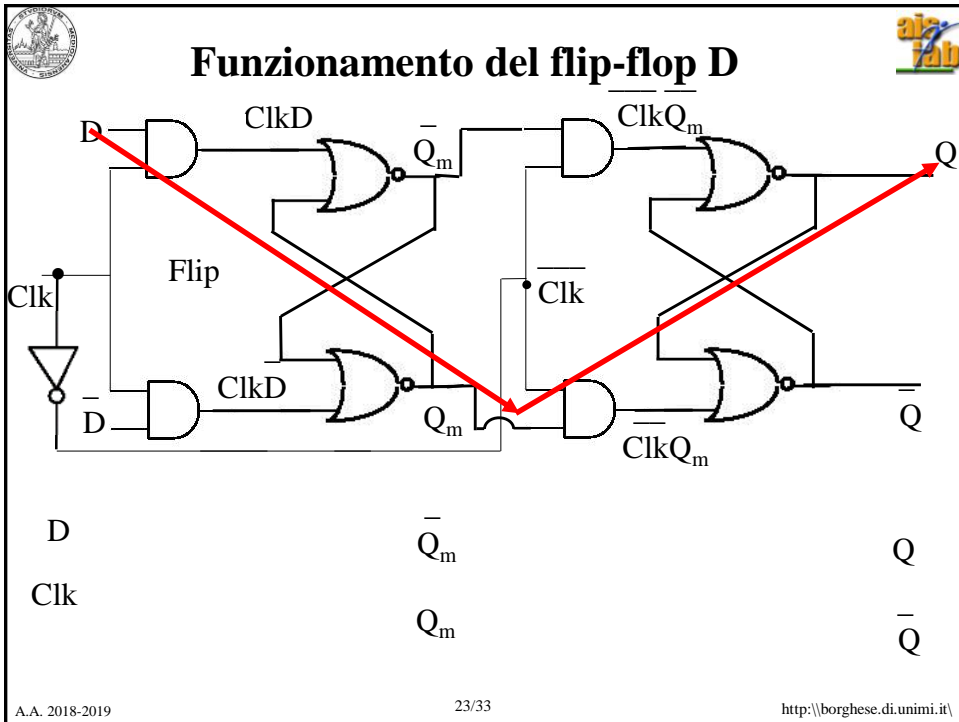

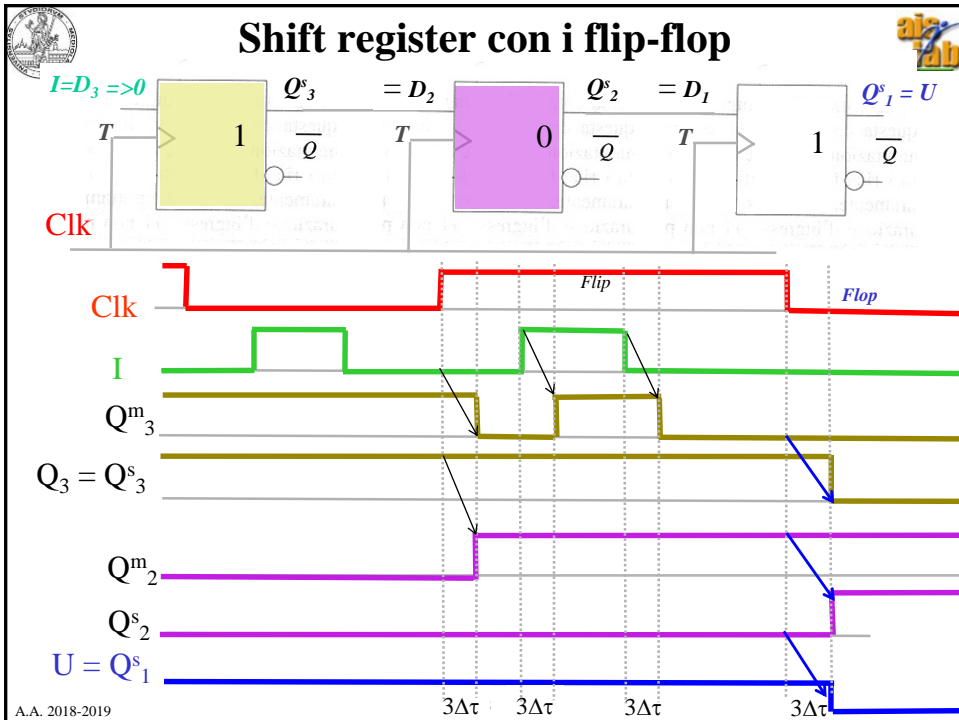

Configurazione master-slave

- Semi-periodo di clock alto:
 - Il master è trasparente: ingresso -> uscita del latch master.
 - Lo slave è “opaco” -> mantiene l’uscita.
 - Lo slave è “disaccoppiato” dal latch master.

- Semi-periodo di clock basso:
 - Il master è opaco: l’uscita del latch master si mantiene.
 - Il master è “disaccoppiato” dall’ingresso esterno.
 - Lo slave è trasparente e porta in uscita l’uscita del latch master.

A.A. 2018-2019 http://borghese.di.unimi.it/



Struttura di un circuito sequenziale

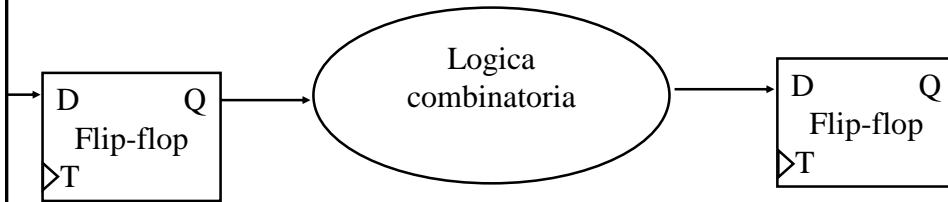

Pone dei problemi di sincronizzazione: la logica combinatoria deve terminare la commutazione in tempo utile.



Temporizzazione di un circuito sequenziale

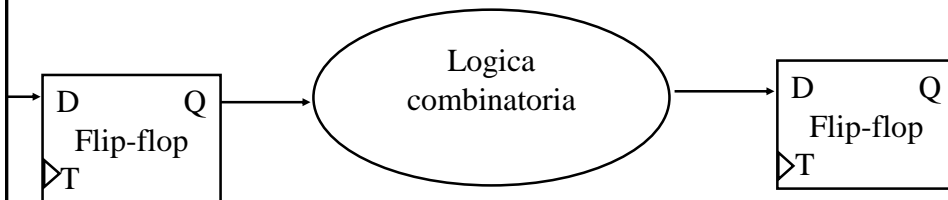

- La logica ha tempo sufficiente per completare la commutazione.
- Il periodo di clock è tale, per cui la commutazione del clock avviene dopo che la logica combinatoria ha terminato tutte le commutazioni.
- Il tempo necessario alla logica combinatoria per commutare è \leq tempo associato al cammino critico.
- Il clock arriva contemporaneamente a tutti i dispositivi sincronizzati.



Temporizzazione: problemi

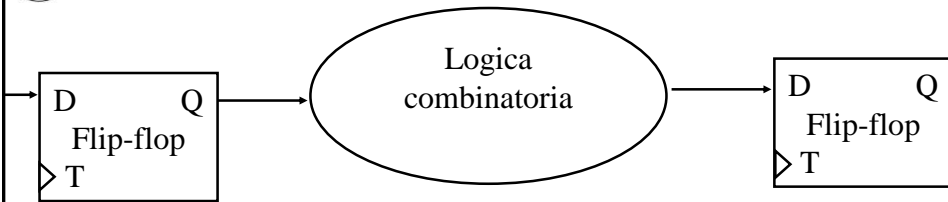

L'input D deve essere stabile intorno alla commutazione del clock:

- **Tempo di set-up:** è il tempo minimo per cui deve rimanere stabile l'input D prima del fronte di clock.
- **Tempo di hold:** è il tempo minimo per cui deve rimanere stabile l'input D dopo il fronte di clock (solitamente trascurabile).

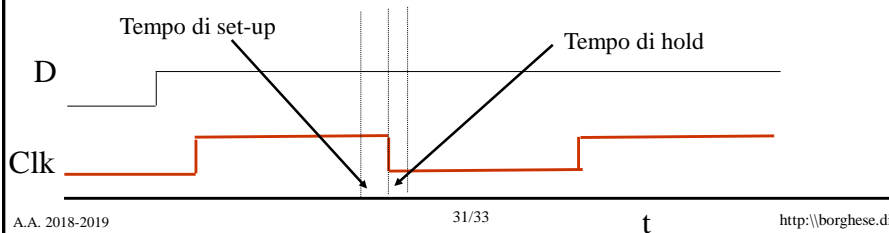

A.A. 2018-2019

31/33

t

<http://borghese.di.unimi.it/>



Temporizzazione: Come si dimensiona il clock



$$T > k * (t_p + t_c + t_s + t_w)$$

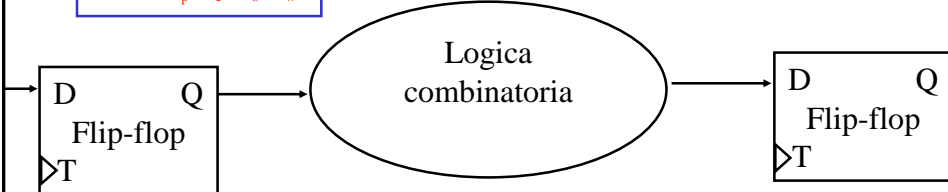

Tempo di propagazione: è il tempo necessario per propagare il segnale nella logica combinatoria (t_p). Il massimo tempo è rappresentato dal cammino critico.

Tempo di skew: ritardo massimo del clock (t_w).

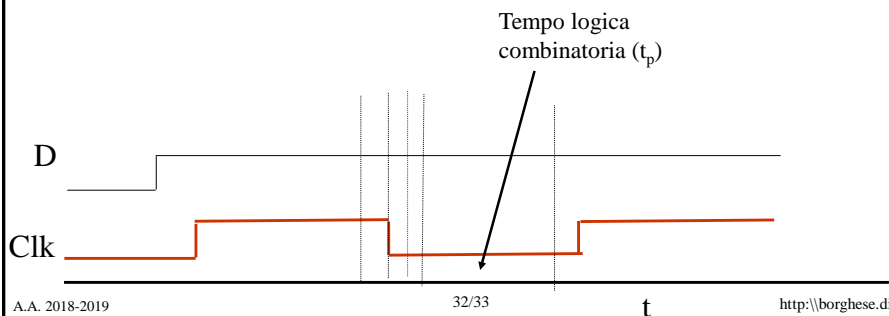

A.A. 2018-2019

32/33

t

<http://borghese.di.unimi.it/>



Sommario



Latch sincroni SR

Latch sincroni D

Flip-flop