



I sommatori

Prof. Alberto Borghese
Dipartimento di Informatica
borgnese@di.unimi.it

Università degli Studi di Milano

Riferimenti: Appendice B5 prima parte.



Sommario

Addizionatori

Addizionatori ad anticipazione di riporto



Implementazione di funzioni algebriche



And, Or, Not per ottenere:

Operazioni algebriche (somme, prodotti, sottrazioni e divisioni) su numeri binari.

Operazioni logiche su numeri binari.



AND e OR su più bit



1	0	0	1
---	---	---	---

AND

1	1	0	0
---	---	---	---

=

1	0	0	0
---	---	---	---

1	0	0	1
---	---	---	---

OR

1	1	0	0
---	---	---	---

=

1	1	0	1
---	---	---	---

Ogni bit viene elaborato separatamente



Operazione di somma



111	← Riporto
1011 +	← Addendo 1
110 =	← Addendo 2

10001	

3 Attori: addendo 1, addendo 2, riporto.

Viene eseguita sequenzialmente da dx a sx.



(Half) Adder ad 1 bit



Tabella della verità della somma:

a b	somma	riporto
0 0	0	0
0 1	1	0
1 0	1	0
1 1	0	1

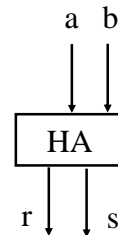

$$s = a \oplus b$$

$$r = ab$$

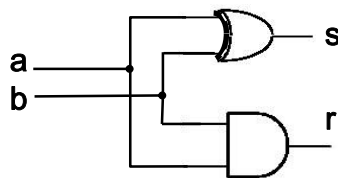

La somma è diventata un'operazione logica!

Cammini critici:
 Somma = 1;
 Riporto = 1;

Complessità
 Somma = 1 porta;
 Riporto = 1 porta;



Full Adder ad 1 bit



Tabella della verità della somma completa:

a	b	r _{in}	somma	riporto
0	0	0	0	0
0	1	0	1	0
1	0	0	1	0
1	1	0	0	1
0	0	1	1	0
0	1	1	0	1
1	0	1	0	1
1	1	1	1	1

$$s = m_1 + m_2 + m_4 + m_7$$

$$r = m_3 + m_5 + m_6 + m_7$$

$$s = a \bar{b} \bar{r}_{in} + a b \bar{r}_{in} + a \bar{b} r_{in} + a b r_{in} =$$

$$= (a \oplus b) \bar{r}_{in} + (ab + \bar{a}\bar{b}) r_{in} =$$

$$= (a \oplus b) \bar{r}_{in} + (a \oplus b) r_{in}$$

$$r_{out} = a \bar{b} r_{in} + a b \bar{r}_{in} + a \bar{b} r_{in} + a b r_{in} = ab + (a \oplus b) r_{in}$$

$$r_{out} = a r_{in} + (a \oplus r_{in}) b$$

Quale è meglio?

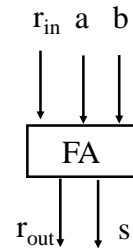

Implementazione circuitale



$$s = (a \oplus b) \bar{r}_{in} + (a \oplus b) r_{in}$$

$$r_{out} = ab + (a \oplus b) r_{in}$$

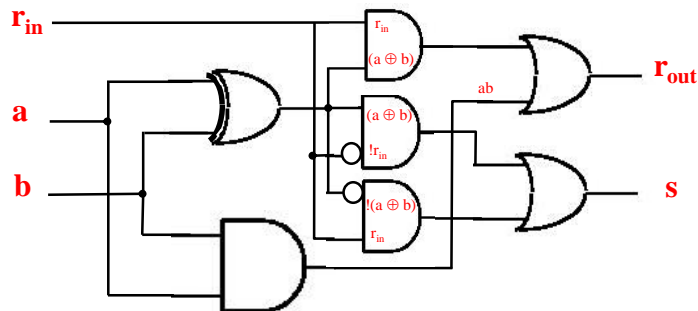

7 porte logiche.

Cammini critici: s -> 3; r_{out} -> 3



Complessità circuitale



- Definire la complessità circuitale e il cammino critico di HA:
 - $s = m1 + m2$
 - $r = m3$
 - Definire la complessità circuitale e il cammino critico di FA:
 - $s = m1 + m2 + m4 + m7$
 - $r = m3 + m5 + m6 + m7$
- Traccia: m1 è un circuito con 3 ingressi ed un'uscita e si può spezzare in due parte AND in cascata.



Semplificazione circuitale



$$s = (a \oplus b)\overline{r_{in}} + \overline{(a \oplus b)}r_{in} = (a \oplus b) \oplus r_{in}$$
$$r_{out} = ab + (a \oplus b)r_{in}$$

6 porte logiche.

Cammini critici: $s \rightarrow 2$; $r_{out} \rightarrow 3$

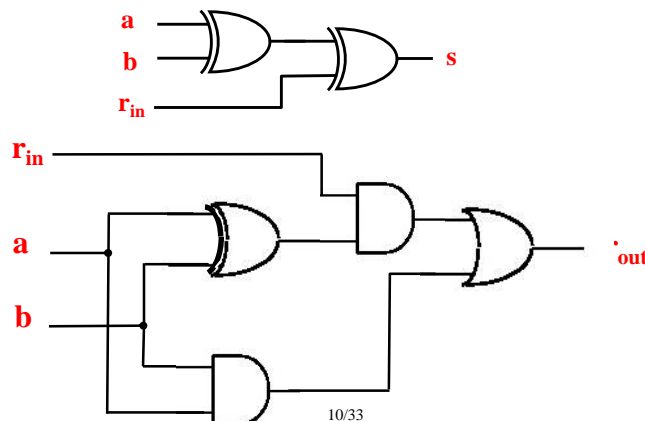



Semplificazione ulteriore



$$s = (a \oplus b)\overline{r_{in}} + \overline{(a \oplus b)}r_{in} = (a \oplus b) \oplus r_{in}$$
$$r_{out} = ab + (a \oplus b)r_{in}$$

5 porte logiche.

Cammini critici: $s \rightarrow 2$; $r_{out} \rightarrow 3$

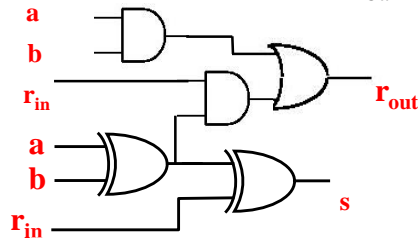

s - rilevatore di (dis)parità

r_{out} - riporto se generato ($a=b=1$) o se r_{in} propagato ($a \oplus b = 1$)



Circuito equivalente



$$s = (a \oplus b)\overline{r_{in}} + \overline{(a \oplus b)}r_{in} = (a \oplus b) \oplus r_{in}$$
$$r_{out} = ab + (a \oplus b)r_{in}$$

5 porte logiche.

Cammini critici: $s \rightarrow 2$; $r_{out} \rightarrow 3$

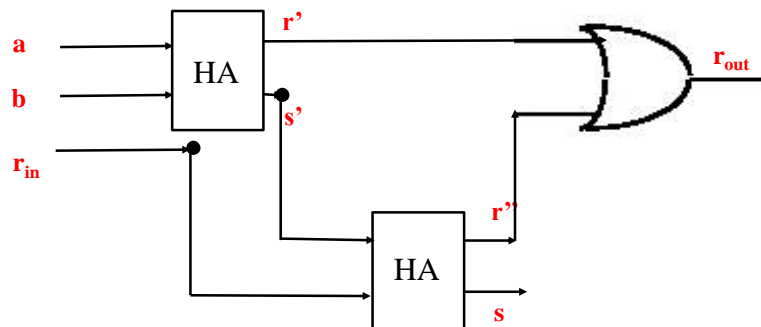



Implementazione mediante PLA



a	b	r_{in}	somma	r_{out}
0	0	0	0	0
0	1	0	1	0
1	0	0	1	0
1	1	0	0	1
0	0	1	1	0
0	1	1	0	1
1	0	1	0	1
1	1	1	1	1

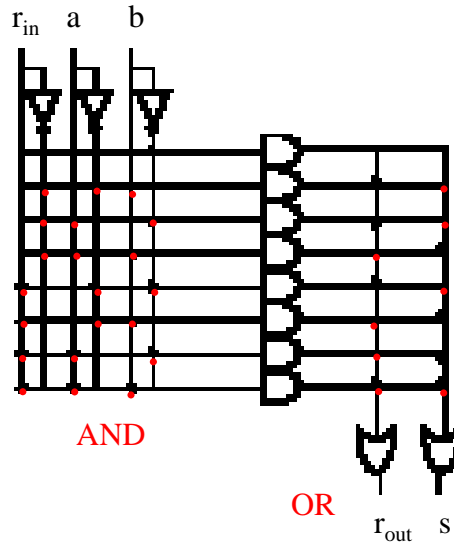

SOP: costruisco i mintermini e li sommo.



Esercizi con ROM e PLA



Implementare il circuito del Full Adder mediante ROM

Scrivere il circuito che esegue la somma di: $3 + 4$ in base 2.

Riportare tutte le uscite delle porte logiche.

Scrivere il circuito che esegue la seguente sottrazione: $5 - 2$ in base

2. Riportare tutte le uscite delle porte logiche.



Sommario



Addizionatori

Addizionatori ad anticipazione di riporto



Circuito della somma

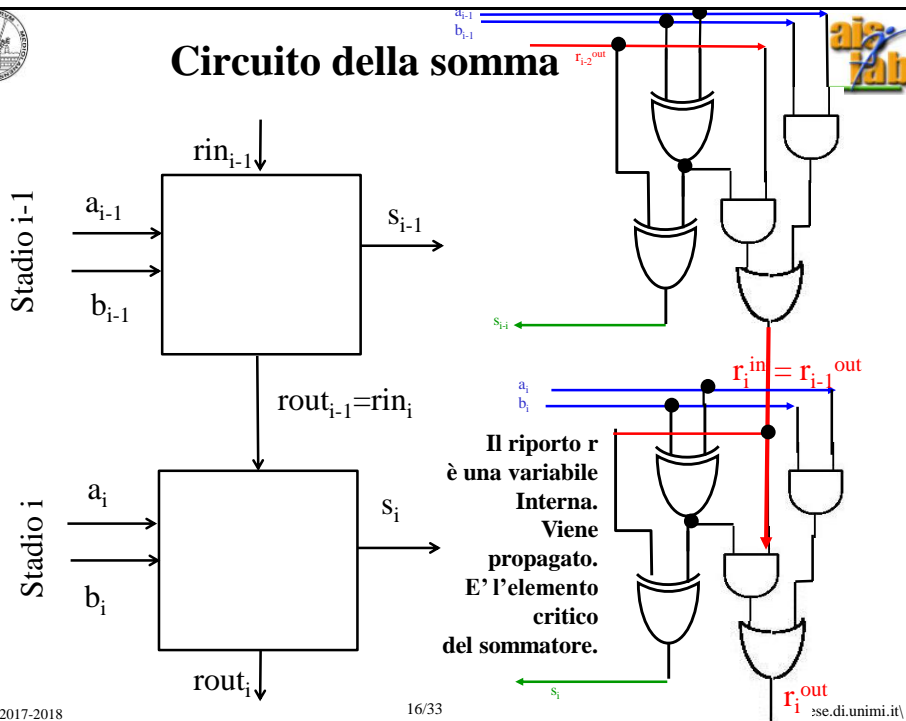



Cammini critici

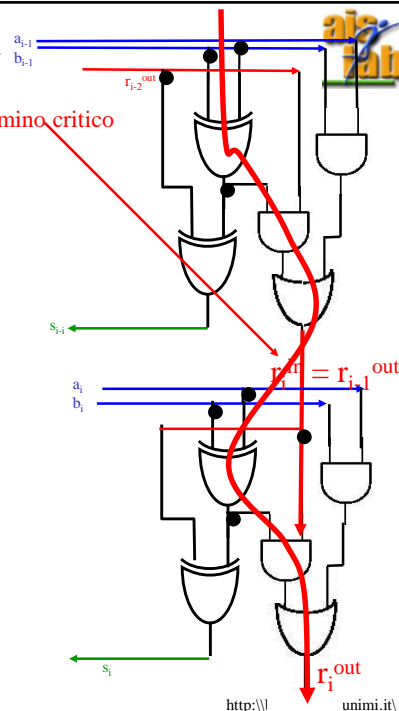

Per ogni stadio:
Somma: 2
Riporto: 3

Per due stadi:
Somma: 2
Riporto: 3 + 3 = 6

Riporto = 3 * N

```

111
1011 +
 110 =
-----
10001

```

Funzionamento
sequenziale



I problemi del full-adder



Il full adder con propagazione del riporto è lento:

- Il riporto si propaga sequenzialmente
caratteristica dell'algoritmo di calcolo
- la commutazione dei circuiti non è istantanea (tempo di commutazione)
caratteristica fisica dei dispositivi
- Soluzioni
modificare l'algoritmo
modificare i dispositivi



Prima possibilità: forma tabellare



Riscrivo le equazioni del riporto in modo non sequenziale. Come?

$$r_{out} = f(a_0, b_0, a_1, b_1, a_2, b_2, a_3, b_3, \dots)$$

Scrivo la tabella della verità dove in uscita ho gli N riporti ed
In ingresso $2 * N$ valori (gli N bit dei 2 addendi).

La tabella della verità ha 2^{2N} righe (per $N=32, \dots$)



Carry look-ahead (anticipazione di riporto)



Approccio strutturato per diminuire la latenza della somma.

$$r_{out} = ab + (a \oplus b) r_{in}$$

Analisi del singolo stadio.

Quando si genera un riporto in uscita?

Quando ho almeno due 1, in ingresso;
cioè tra r_{in} , a e b .

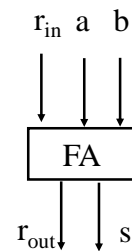

11000 riporto

1101 +

100 =

10001



Propagazione e generazione



Ho riporto quando ho almeno due 1, in ingresso; cioè tra r_{in} , a e b .

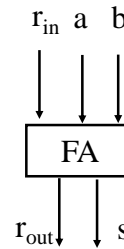

Osservazioni:

- Viene generato un riporto dallo stadio i , qualsiasi sia il riporto in ingresso se $a = b = 1 \Rightarrow g_i = a_i b_i$.
- Viene generato un riporto allo stadio i , se il riporto in ingresso è $= 1$ ed una delle due variabili in ingresso è $= 1 \Rightarrow$ se $p_i = (a_i \oplus b_i) \Rightarrow$ viene generato riporto se $p_i r_i^{in} = 1$ (p_i propaga il segnale di riporto r_i^{in}).

Quando sia la condizione 1) che la condizione 2) è verificata?
Cosa succede se entrambe le condizioni sono verificate?



Esempio



Sono interessato ad r_4^{out} . Supponiamo $r_0^{in} = 0$.

r_{in}	0 0 0 0 0 0 0	0 1 1 1 0 0 0	0 1 1 1 0 0 0
a	1 0 1 0 1 1 0 1 +	1 0 1 0 1 1 0 1 +	1 0 1 1 1 1 0 1 +
b	1 0 0 0 0 =	1 1 0 1 0 =	1 1 0 0 0 =
	-----	-----	-----
	1 0 1 1 1 1 1 1	1 1 1 0 0 1 1 1	1 1 0 1 0 1 0 1

$$r_5^{in} = r_4^{out} = 0$$

$$r_5^{in} = r_4^{out} = 1$$

$$r_5^{in} = r_4^{out} = 1$$

Per propagazione

Per generazione

$$p_4 = (a_4 \oplus b_4) r_4^{in}$$

$$g_4 = a_4 b_4$$



Sviluppo della funzione logica riporto



$$r_i^{\text{out}} = ab + (a \oplus b) r_i^{\text{in}}$$

$$\downarrow \quad \swarrow$$

$$r_i^{\text{out}} = g_i + p_i r_i^{\text{in}}$$

$$r_0^{\text{out}} = g_0 + p_0 r_0^{\text{in}}$$

$$r_1^{\text{out}} = g_1 + p_1 r_1^{\text{in}} = g_1 + p_1 g_0 + p_1 p_0 r_0^{\text{in}}$$

$\begin{array}{r} r_1^{\text{out}} \swarrow 111 \\ 1001 + \\ 10 = \\ \hline 1100 \\ \\ g_0 = 0 \\ p_0 = p_1 = 1 \end{array}$	$\begin{array}{r} r_1^{\text{out}} \swarrow 110 \\ 1001 + \\ 11 = \\ \hline 1100 \\ \\ g_0 = 1 \\ p_1 = 1 \end{array}$	$\begin{array}{r} r_1^{\text{out}} \swarrow 10 \\ 1010 + \\ 11 = \\ \hline 1100 \\ \\ g_1 = 1 \end{array}$
--	--	--



Sviluppo della funzione logica riporto



$$r_i^{\text{out}} = ab + (a \oplus b) r_i^{\text{in}}$$

$$\downarrow \quad \swarrow$$

$$r_i^{\text{out}} = g_i + p_i r_i^{\text{in}}$$

$$r_0 = g_0 + p_0 r_0$$

$$r_1 = g_1 + p_1 r_0 = g_1 + p_1 g_0 + p_1 p_0 r_0$$

$$r_2 = g_2 + p_2 r_1 = g_2 + p_2 (g_1 + p_1 g_0 + p_1 p_0 r_0) = g_2 + p_2 g_1 + p_2 p_1 g_0 + p_2 p_1 p_0 r_0$$

$$r_3 = g_3 + p_3 r_2 = g_3 + p_3 (g_2 + p_2 g_1 + p_2 p_1 g_0 + p_2 p_1 p_0 r_0) = g_3 + p_3 g_2 + p_3 p_2 g_1 + p_3 p_2 p_1 g_0 + p_3 p_2 p_1 p_0 r_0$$



Determinazione del cammino critico.



$$r_3 = g_3 + p_3 r_2 = g_3 + p_3(g_2 + p_2 g_1 + p_2 p_1 g_0 + p_2 p_1 p_0 r_0) =$$

$$g_3 + p_3 g_2 + p_3 p_2 g_1 + p_3 p_2 p_1 g_0 + p_3 p_2 p_1 p_0 r_0.$$

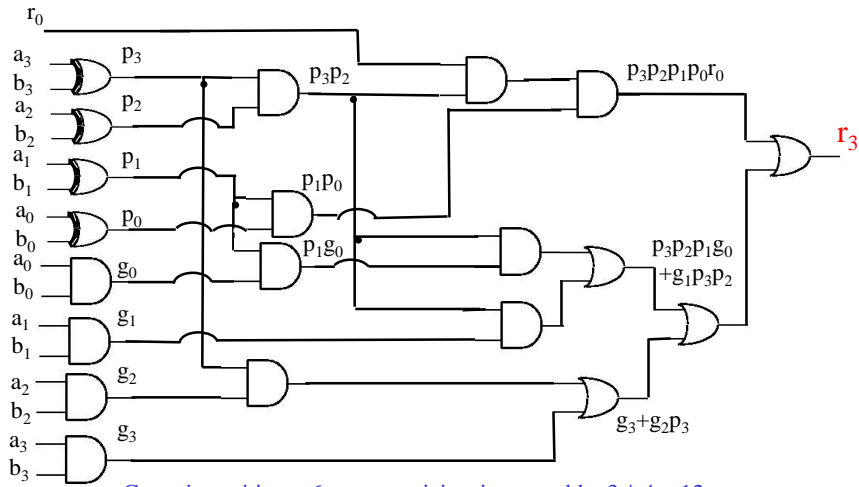

Determinazione la complessità.



$$r_3 = g_3 + p_3 r_2 = g_3 + p_3(g_2 + p_2 g_1 + p_2 p_1 g_0 + p_2 p_1 p_0 r_0) =$$

$$g_3 + p_3 g_2 + p_3 p_2 g_1 + p_3 p_2 p_1 g_0 + p_3 p_2 p_1 p_0 r_0.$$

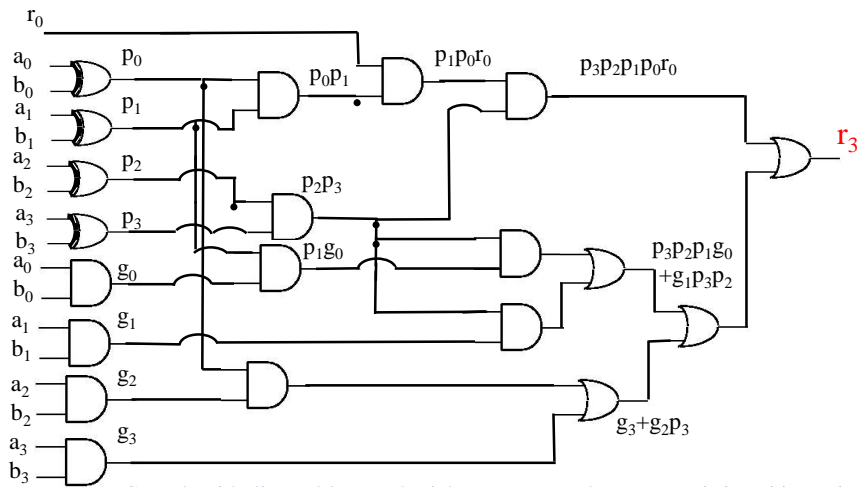



Complessità aggiuntiva per gli altri bit di riporto



$$r_2 = g_2 + p_2 r_1 = g_2 + p_2(g_1 + p_1 g_0 + p_1 p_0 r_0) = \\ g_2 + p_2 g_1 + p_2 p_1 g_0 + p_2 p_1 p_0 r_0$$

Complessità aggiuntiva pari a 5 porte logiche.

$$r_1 = g_1 + p_1 r_0 = g_1 + p_1 g_0 + p_1 p_0 r_0$$

Complessità aggiuntiva pari a 2 porte logiche.

Complessità aggiuntiva totale: 7 porte logiche.



Complessità aggiuntiva per i bit di somma



$$s_k = (a_k \oplus b_k) \oplus r_{kin} = p_k \oplus r_{kin}$$

Ogni bit di somma aggiunge una porta logica XOR =>
La complessità aumenta di $N * 1 = 4$ porte logiche.

Un CLA su 4 bit ha quindi una complessità di 31 porte logiche.



Quanto si guadagna con l'anticipazione del riporto per N stadi?



Cammino critico per le variabili interne:

$$r_0^{\text{out}} \Rightarrow 3$$

$$r_1^{\text{out}} \Rightarrow 4$$

$$r_2^{\text{out}} \Rightarrow 5$$

Cammino critico per le variabili esterne:

$$r_3^{\text{out}} \Rightarrow 6$$

$$s_3 \Rightarrow 6 \text{ NB la prima porta XOR è in comune con } r_2^{\text{out}}$$

$$s_2 \Rightarrow 5 \text{ NB la prima porta XOR è in comune con } r_1^{\text{out}}$$

$$s_2 \Rightarrow 4 \text{ NB la prima porta XOR è in comune con } r_0^{\text{out}}$$

$$s_0 \Rightarrow 2$$

Cammino critico scala come $CC_{1 \text{ stadio}} * \log(N)$



Addizionatori modulari



La complessità del circuito è tollerata per piccoli n.

Circuiti sommatore indipendenti si hanno per 4 bit.

Moduli elementari.

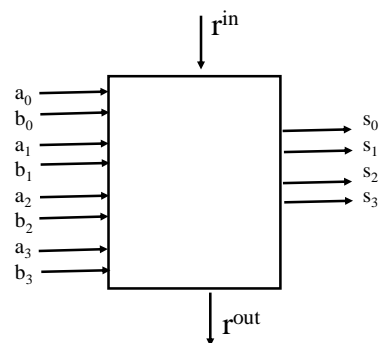

Come si ottiene la somma?

Collegando in cascata i moduli (sommatori elementari).

Cammino critico = $6 * N/4$. Per 32 bit, 48.

Per confronto, senza parallelizzazione, per 32 bit, $N * 3 = 96$.



Architettura interna

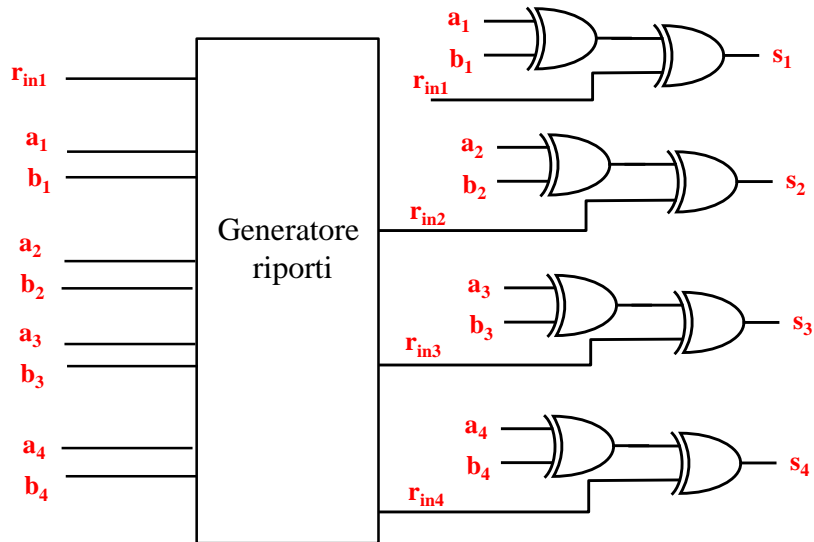

Addizionatori modulari::esempio



Occorre sommare 2 variabili, A e B, su $N = 32$ bit
 Ho a disposizione due sommatore su 16 bit.

Come si ottiene la somma?

Fondamento delle estensioni architetturali SSE

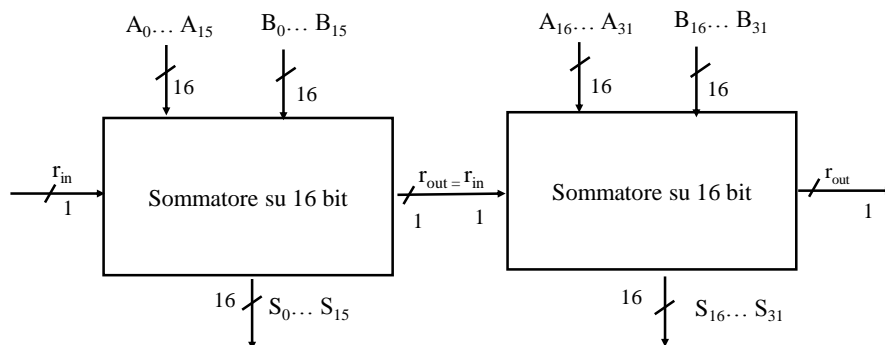



Sommario



Addizionatori

Addizionatori ad anticipazione di riporto